

Division of Foundations® Worldwide, Inc.

• 7001 Wooster Pike, Medina, OH 44256 USA • PH: 1 877.716.2757 (U.S. Only) or +1 330.722.5033 • FAX: +1 330.722.5037
 • www.childcraftbaby.com

Assembly Directions and Parts List

Directions for maintenance, cleaning, storage and use of your Changing Table are also included.

- **BEFORE STARTING THE ASSEMBLY PROCEDURE, READ ALL DIRECTIONS WITH CARE.**
- **YOU WILL NEED THE FOLLOWING FOR THE ASSEMBLY OF YOUR CHANGING TABLE:**
 #2 PHILLIPS SCREWDRIVER - FLAT TIPPED SCREWDRIVER

Parts packed in carton and hardware bag

A (1) Allen Wrench



B (16) Allenhead Bolts

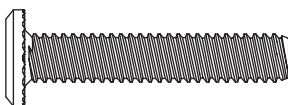

C (2) Allenhead Bolts

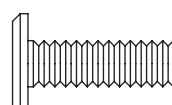

D (2) Hex Nut



E (2) Nylon Washer

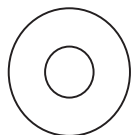

F (1) Dressing Pad

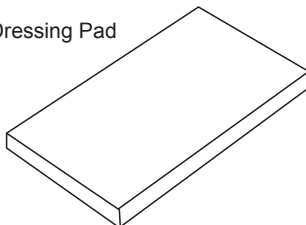

G (1) Belt



P (1) Tip Kit

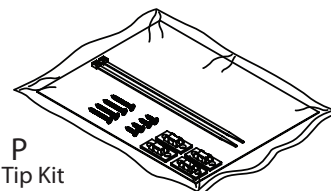

Parts packed in carton

H (1) End Assembly-Right

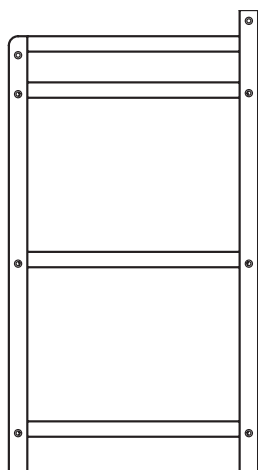

I (1) End Assembly-Left

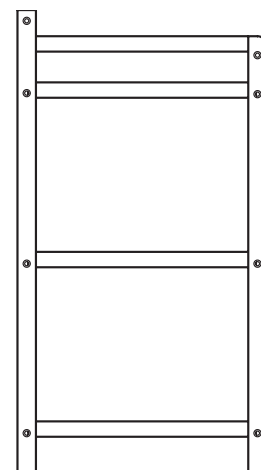

J (1) Top Back Assembly

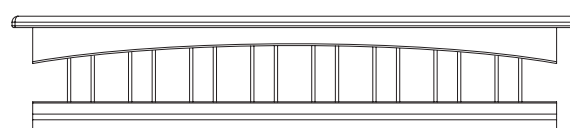

N (1) Top Shelf

Holes in face

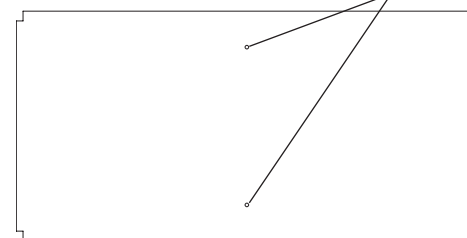

K (1) Top Front Rail

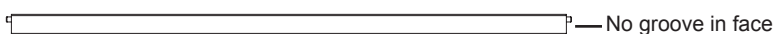

L (1) Top Shelf Front Rail

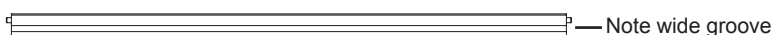

M (4) Lower Front Back Rail



O (2) Lower Shelf



PREPARATION

Carefully remove and lay out all hardware and parts. Check quantities and match the Hardware List and the Parts List. **NOTE: During the assembly process, when using screws or bolts, check each with the PARTS ENCLOSED IN HARDWARE BAG list by letter and size identification. Place each screw or bolt on the diagram of the item which is sketched actual size. Be sure to use the proper size specified in the assembly directions.** If any parts are missing or broken or you need assistance with assembly, DO NOT return the product to your dealer. Call Foundations® for assistance at 1 877.716.2757 (U.S. Only) or +1 330.722.5033 (Monday through Friday, 9:00 a.m.– 4:00 p.m. Eastern Time). Before making this contact identify your Changing Table by the model identification number stamped on the label attached to underside of **Top Shelf N**. Make note of all identification numbers and include this information with your request. **DO NOT SUBSTITUTE PARTS!** Record your model identification number here for future identification:

Model # _____

STEP 1 - DIAGRAM 1: END ASSEMBLY

Parts **J**, **K**, **L** and **M** will be attached to End Assembly - Right **H** as shown. Parts **J**, **K**, **L** and **M** each have metal threaded inserts which will accept installation of Allenhead Bolt **B**. Align parts together and insert locator dowels on parts **K** and **L** into receiving holes in End Assembly - Right **H**. Insert Bolts **B** through assembly holes in part **H** and thread into metal inserts in each of parts **J**, **K**, **L** and **M**. Once bolts are installed, tighten securely using Allenwrench **A**. A total of eight (8) Bolts **B** are installed during this step.

NOTE: Grooves in face of part **M** are closer to top edge during installation. Grooves on all parts should be positioned toward inside.

Allenhead Bolts **B** installed from outside face of End Assembly - Right **H** into receiving holes and into threaded inserts.

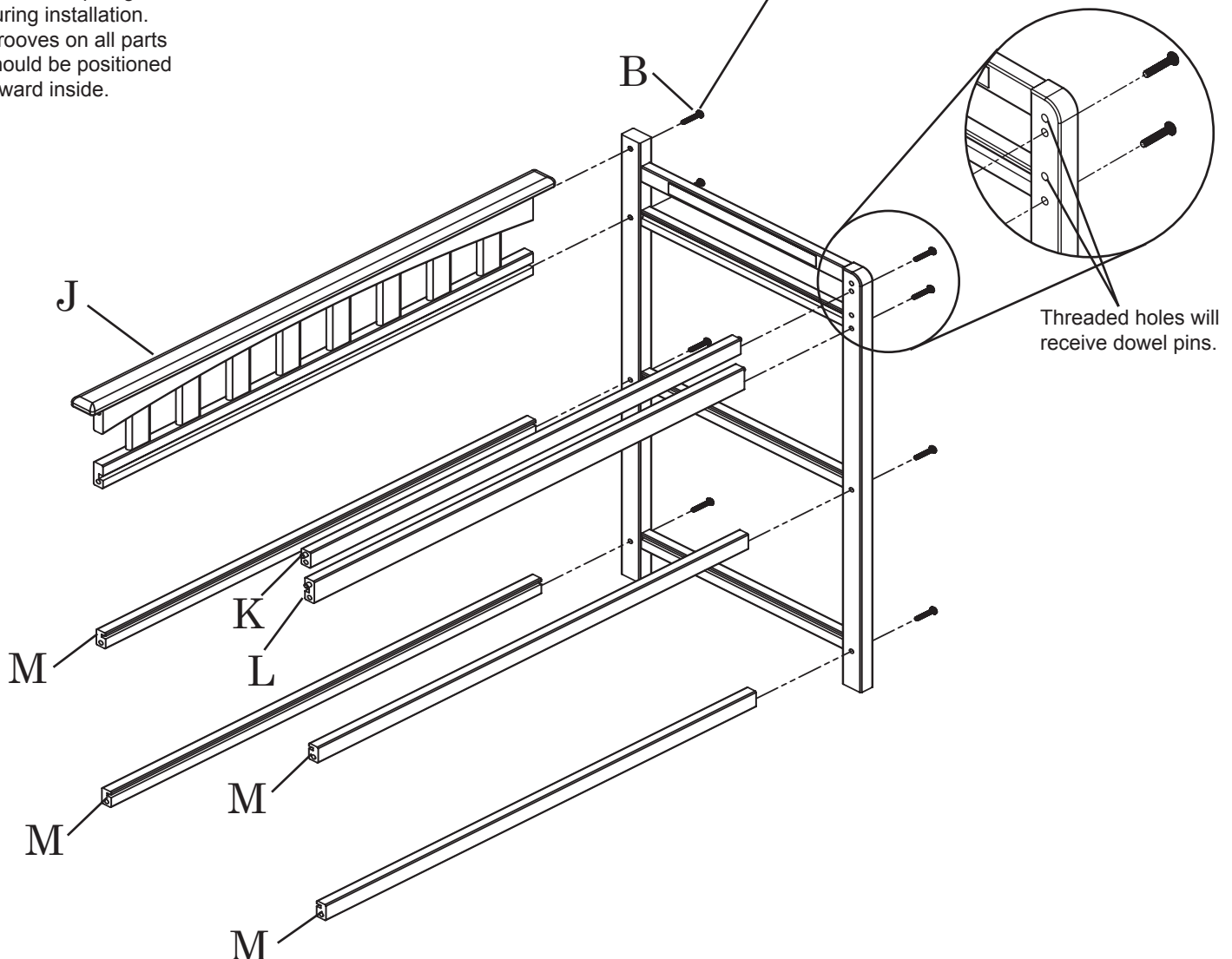

STEP 2 - DIAGRAM 2: SHELF ASSEMBLY

Slide **Shelves O** and **N** into receiving grooves as shown.

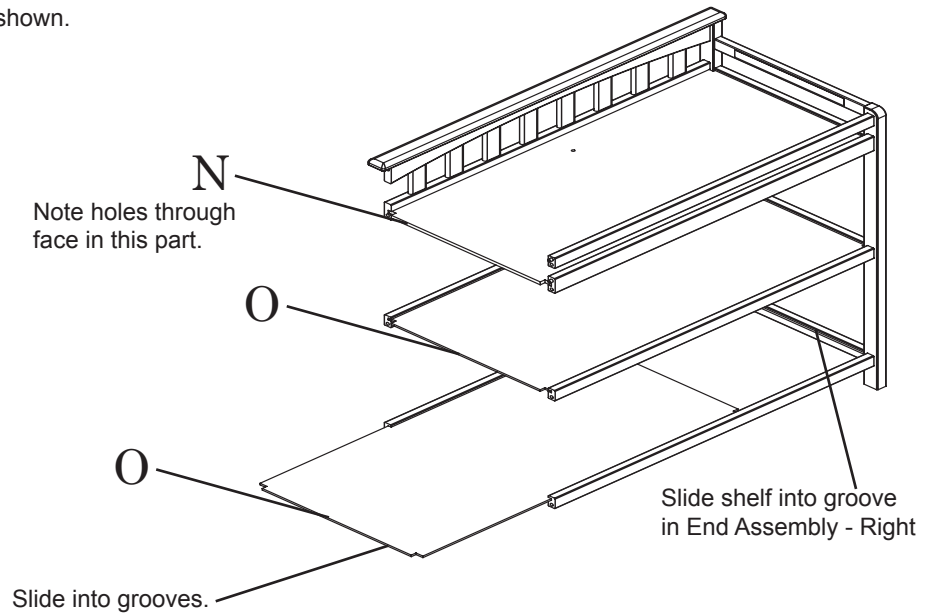

STEP 3 - DIAGRAM 3: ATTACHING END ASSEMBLY-LEFT TO ASSEMBLED END ASSEMBLY-RIGHT

Attach End Assembly - Left **I** following the same process as complete during Step 1. Also guide shelves **O** and **N** into the receiving grooves in End Assembly - Left **I**. Once all dowels and shelves are seated into their proper location install eight (8) Allenhead Bolts **B** through End Assembly - Left **I** and thread into metal threaded inserts. Tighten all bolts securely using Allen Wrench **A**.

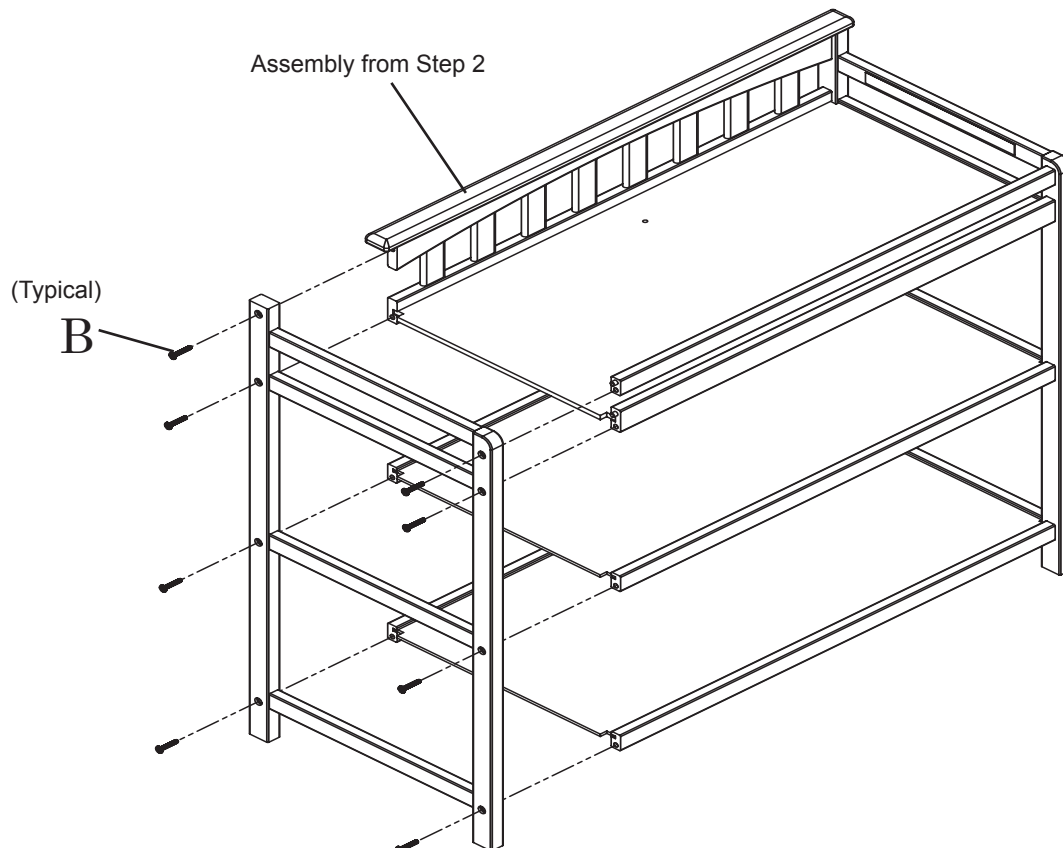

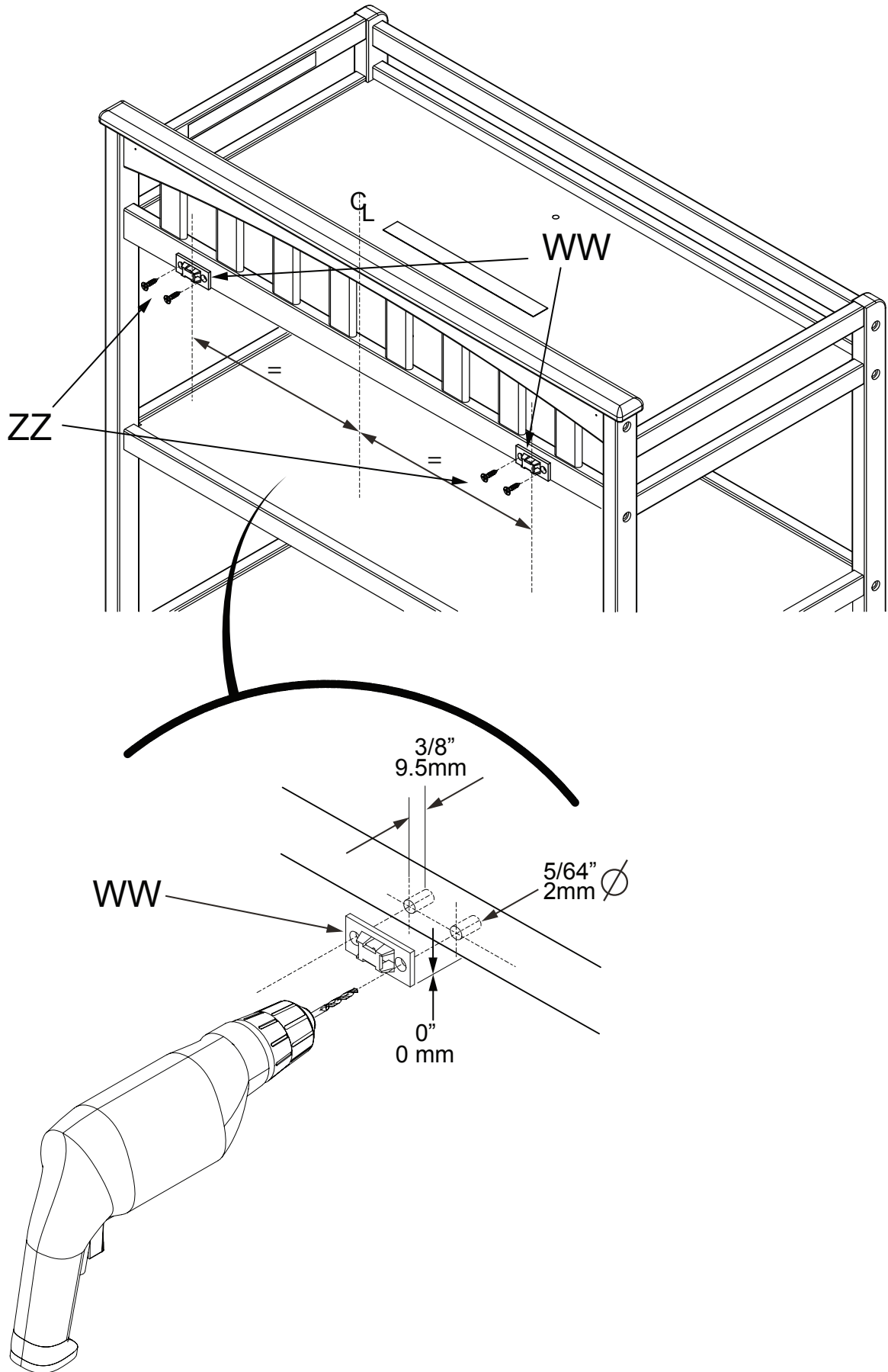

Determine location of 2 wall studs if possible. If not possible, purchase an appropriate anchor system as explained in Step 2 of the WALL STUD SAFETY BRACKET INSTRUCTIONS.
 Brackets mounted on Dressing Table must be equal distant from the center (CL) of Dressing Table.

STEP 5 - DIAGRAM 5: ATTACHING AND Using Restraint Belt

Align the holes in each end of **Restraint Belt G** with the holes in the **Top Shelf N**. Attach by inserting Washer **E** on Bolt **C** then through the hole in the **Top Shelf N**. Secure using a Hex Nut **D** threaded onto **Allenhead Bolt C** from the underside as shown. Tighten securely.

NOTE: Style of Dressing Table may vary.

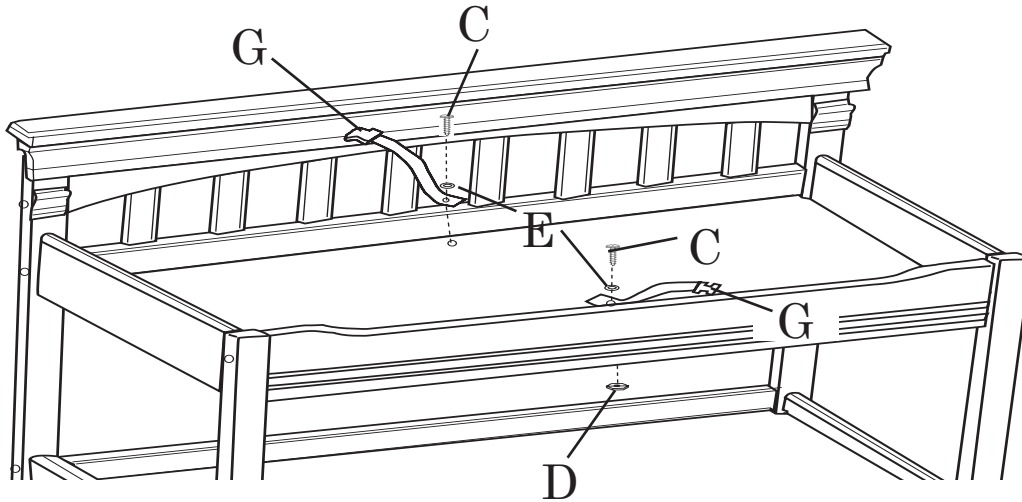

Place the Foam Dressing Pad **F** on Top Shelf as shown before using. Read all **WARNINGS** before use.

USE OF RESTRAINT BELT

- * Lay infant on Foam Dressing Pad.
- * Restraint Belt will be placed over the infant's torso.
- * Insert the buckle ends of each belt into each other until a "CLICK" is heard and ends become locked together.
- * Gently pull the free end of the Belt strap to adjust a snug fit around the infant.

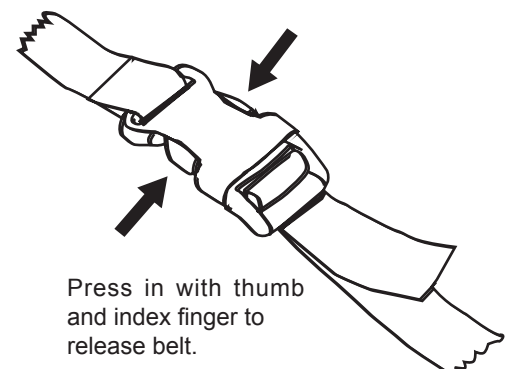
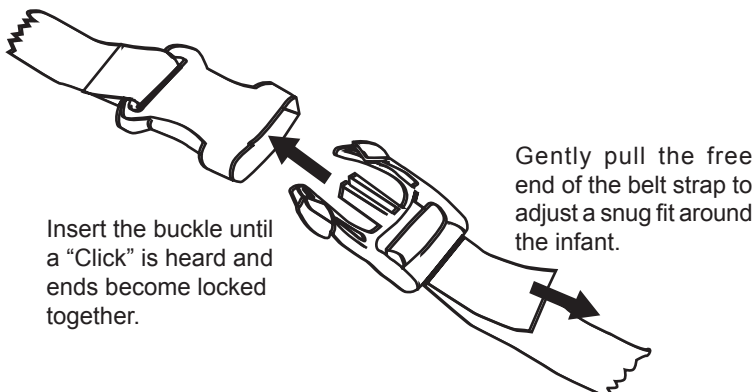
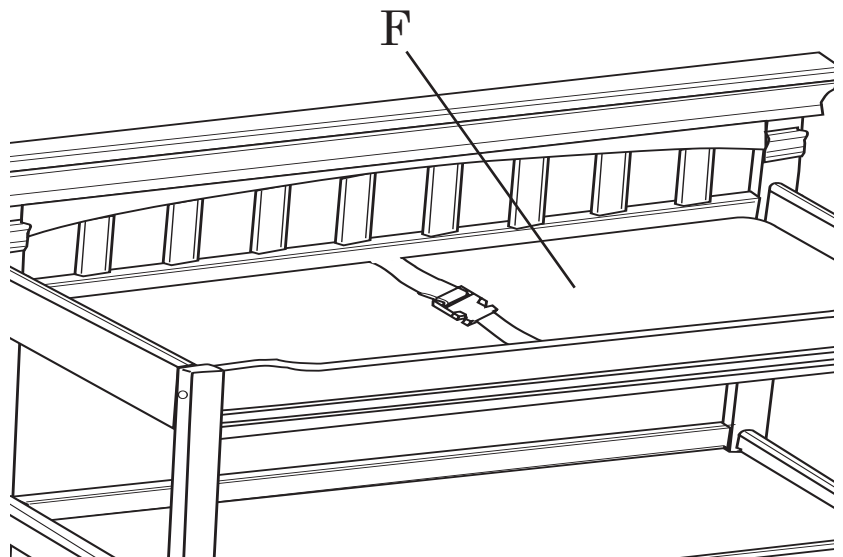



WARNING

- Read all instructions before use of the changing table.
- Failure to follow these warnings and assembly instructions could result in serious injury or death.
- **FALL HAZARD:** Children have suffered serious injuries after falling from changing tables. Falls can happen quickly.
- **STAY** within arm's reach.
- Do not use this changing table as a changing area if the rails are loose, broken or missing.
- Do not use the changing table if it is damaged or broken.
- Do not allow the child or children to climb on this changing table.
- Upon completion of assembly be sure all screws, bolts and fastening devices have been tightened securely. A frequent check should be made of all screws, bolts and fastening devices and tighten if needed.
- Do not use this changing table as a changing area when the security belts are missing or not properly secured.
- Do not use the changing area of this changing table when the child reaches 30 pounds.
- Keep instructions for future use.
- This product is not intended to be used as a changing table without the dressing pad and securing belt provided. Use of this product without this may result in death or serious injury to your child from falling. Follow all instructions on attaching and using the securing belt.

• **MAINTENANCE OF YOUR CHANGING TABLE:** Upon completion of assembly be sure all screws, bolts and fastening devices have been tightened securely. A frequent check should be made of all screws, bolts and fastening devices and tightened if needed. Before each usage or assembly, inspect for damaged hardware, loose joints, missing parts or sharp edges. **DO NOT** use if parts are missing or broken. Contact Foundations® for assistance at 1 877.716.2757 (U.S. Only) or +1 330.722.5033 (Monday through Friday, 9:00 a.m.– 4:00 p.m. Eastern Time). Include Model Identification Number with your request which you recorded on the back of your Changing Table. **DO NOT SUBSTITUTE PARTS.** DO NOT MAKE ANY ALTERATIONS NOT DESCRIBED IN THESE ASSEMBLY DIRECTIONS.

• **CLEANING INSTRUCTIONS FOR CHANGING TABLE:** Mix together a mild solution of gentle dishwashing liquid and water, apply to surface using a soft clean cloth lightly dampened in the solution. Rinse with clear water again using a soft clean cloth, then dry all surfaces thoroughly with a soft dry cloth. **NO ABRASIVE CLEANERS, SCOURING PADS, STEEL WOOL, OR COARSE RAGS SHOULD BE USED TO CLEAN THIS FINE FURNITURE.**

• **STORAGE AND USE OF CHANGING TABLE:** After completing the assembly process you are advised to read and be aware of all **WARNINGS, CAUTIONS, CLEANING, STORAGE, USE AND MAINTENANCE** notices contained in this set of directions. When storing the Changing Table use **CAUTION** as extreme temperature or humidity changes could be harmful. Use **CAUTION** when a vaporizer is in use, always aim vapor stream away from the Changing Table as well as away from any wood furniture item.



Division of Foundations Worldwide, Inc.
5216 Portside Dr.
Medina, OH 44256 USA
Telephone: 1 877.716.2757 (U.S. Only)
or +1 330.722.5033
Fax: +1 330.722.5037
www.childcraftbaby.com