

## Forte Chest

### Model Covered: F04302

**KEEP INSTRUCTIONS FOR FUTURE USE.**

**FOR CUSTOMER SERVICE CALL  
 330-723-0599. DO NOT CALL  
 RETAILER OR RESELLER FOR SERVICE  
 AS THEY ARE NOT AUTHORIZED TO  
 RESOLVE ANY SERVICE ISSUES.**

**FOR WARRANTY AND FEDERAL SAFETY  
 STANDARD COMPLIANCE CERTIFICATES,  
 PLEASE VISIT OUR WEBSITE AT  
[www.childcraftbaby.com](http://www.childcraftbaby.com)**

### **ASSEMBLY ASSISTANCE**

**IMPORTANT: Retain for future reference and read carefully.**

Child Craft strives for the highest quality in our products but occasionally a missing part or problem can occur during assembly.

If any parts are missing or broken or you need assistance with assembly, DO NOT return the product to your dealer. Go to our website at [www.childcraftbaby.com](http://www.childcraftbaby.com) or call Child Craft for assistance at 1-330-723-0599 (Monday through Friday, 9:00 a.m.– 4:00 p.m. Eastern Time). Please have the model number and manufacture date available when you call or write us at:  
 Child Craft, 5216 Portside Dr., Medina, OH 44256

### **ASSEMBLY INSTRUCTIONS**

- Adult assembly required.
- Read all instructions BEFORE assembly and USE of product.
- Unpack carton, remove packing materials, including polybag. Identify and check all parts.

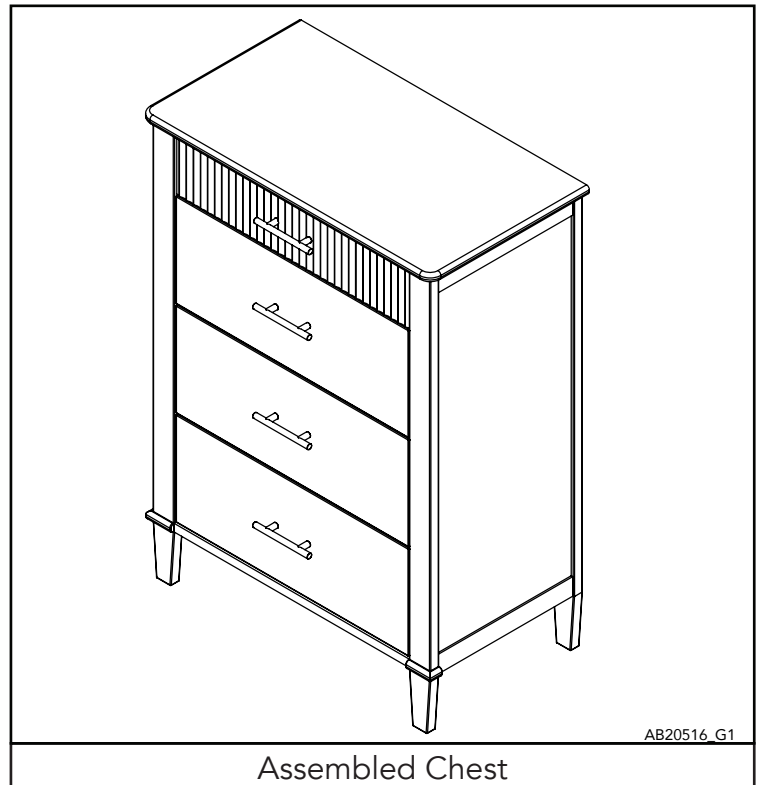

Assembled Chest

Record the information for your product here:

Model number: \_\_\_\_\_

Manufacture date: \_\_\_\_\_

PO number: \_\_\_\_\_

## PARTS LIST

Part Description	Part Number	Qty.
A. Left Side	23103217	1
B. Right Side	23103221	1
C. Bottom	23103201	1
D. Top	23103204	1
E. Front Connector Rail	23103207	1
F. Rear Connector Rail	23103208	1
G. Back	23103209	2
H. Drawer Support Rail	23103151	4
I. Drawer Bottom	23103210	4
J. Top Drawer Back	23103211	1
K. Top Left Drawer - Side	23103155	1
L. Top Right Drawer - Side	23103156	1
M. Top Drawer Front	23103215	1
N. Bottom Left Drawer - Side	23103163	3
O. Bottom Right Drawer - Side	23103164	3
P. Bottom Right Drawer - Front	23103213	3
Q. Bottom Drawer Back	23103212	3
AA. Wood Screw	11201451	28
BB. Dowel	11201360	14
CC. Safety Bracket Kit	11201229	1
DD. Drawer Pull	11201563	4
EE. Allen Head Bolt 50mm Long	11200879	6
FF. Allen Head Bolt 30mm Long	11201220	6
GG. Screw	11201436	8
HH. Flat Head Screw	11201385	40
II. Allen Wrench	11201223	1
JJ. Half Moon Connector	11201222	2

## PREPARATION

Carefully remove and lay out all hardware and parts. Check quantities and match the parts list. Construct furniture on an even flat floor.

Note: During the assembly process whenever using screws or bolts, check each with the parts list by letter and size identification. Place each screw or bolt on the diagram of the item which is sketched actual size. Be sure to use the proper size specified in the assembly directions. If any parts are missing or broken or you need assistance with assembly, **DO NOT return your product to the dealer.** Please identify the furniture by the model number identification stamped on the assembly when you call or write to Child Craft. Make note of all identification numbers and include this information with your request.

**DO NOT Substitute Parts!**

**IMPORTANT NOTE: During the assembly process, it may be necessary to temporarily loosen fasteners installed in an earlier step to allow adjustments in proper alignment for other parts. Always remember to retighten securely after this process.**

## SUGGESTED TOOLS

#2 Medium Straight Screwdriver

Furniture Parts

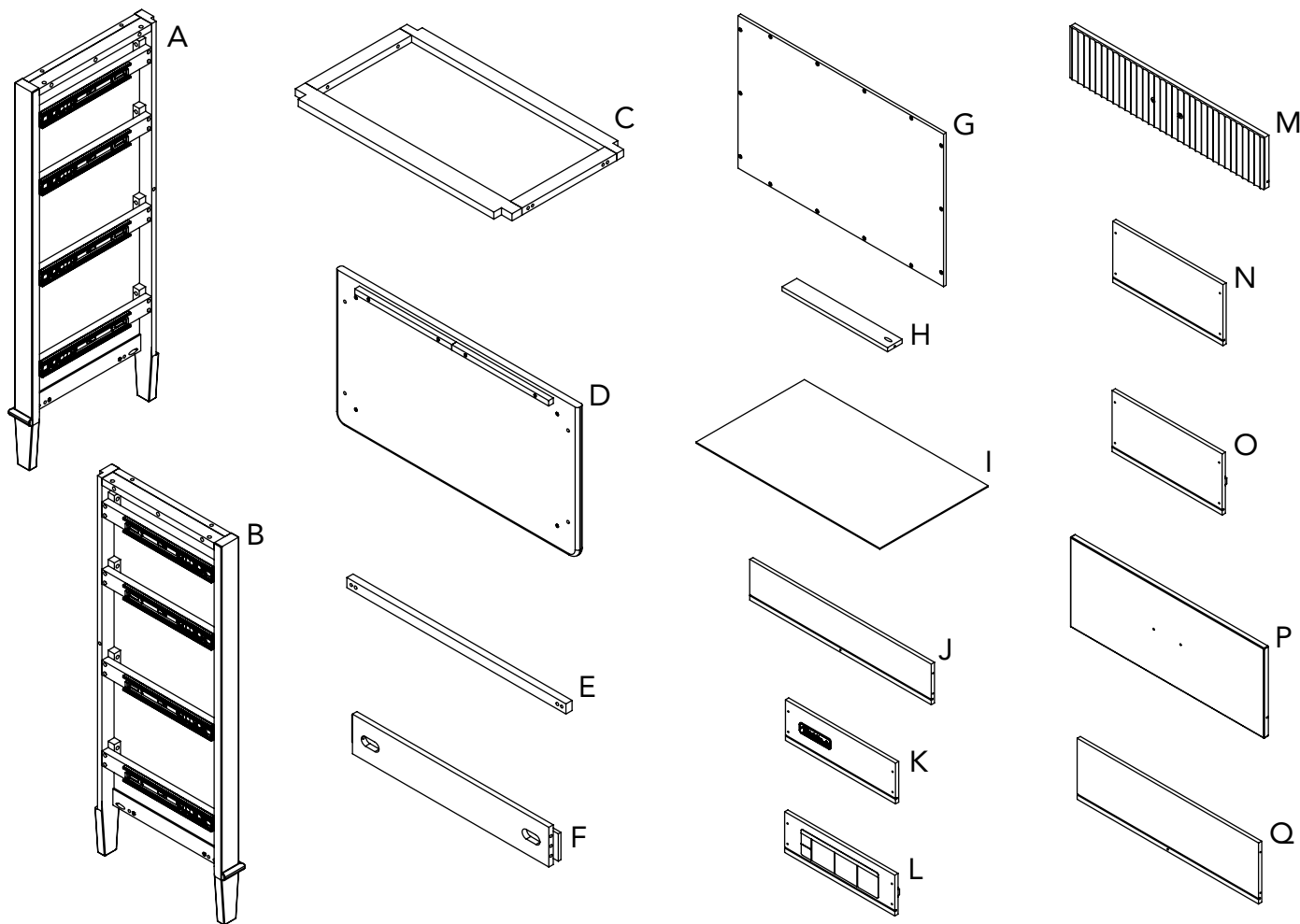

AB20516\_G2

Hardware Package

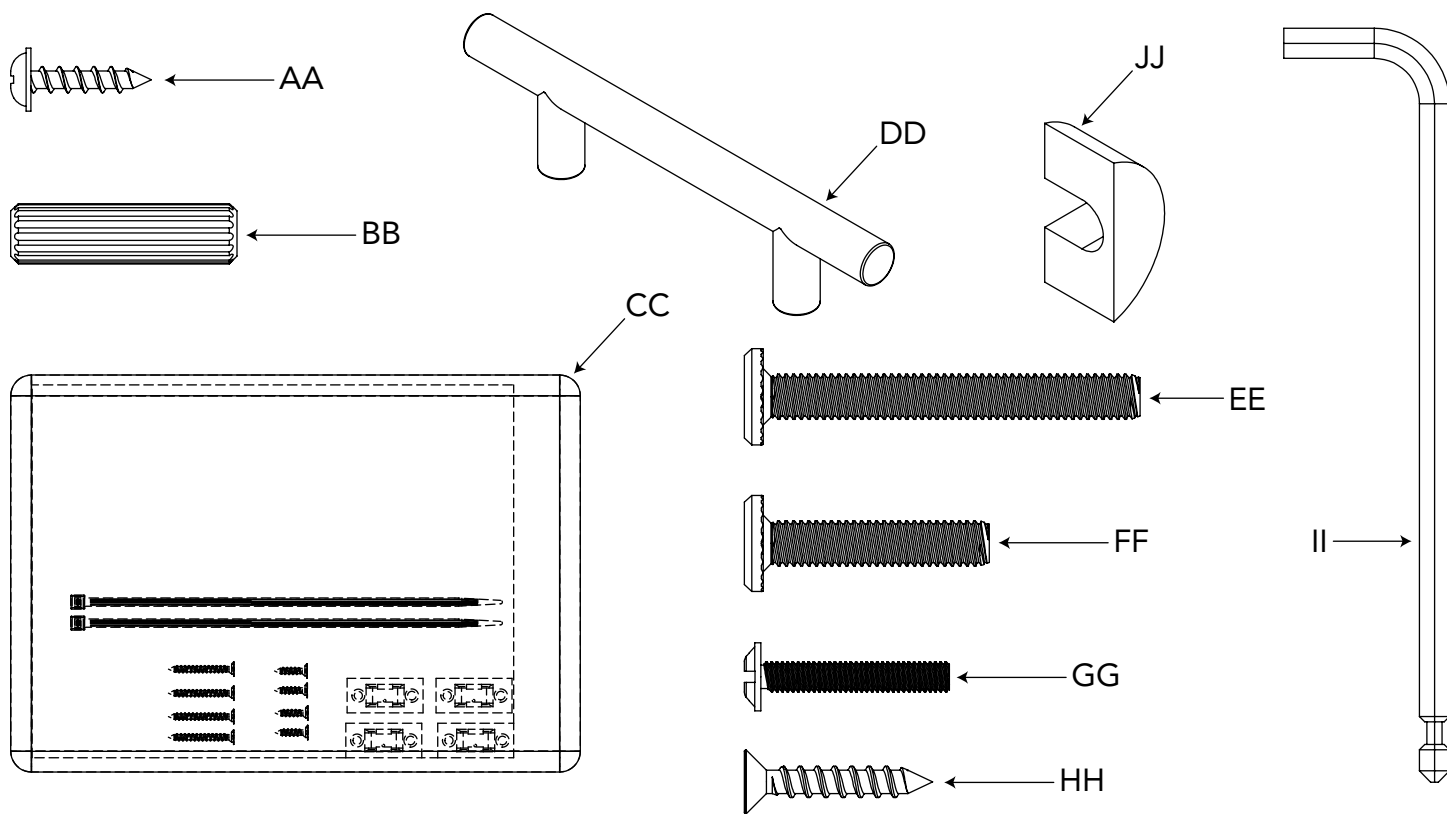

AB20516\_G3

# STEP 1

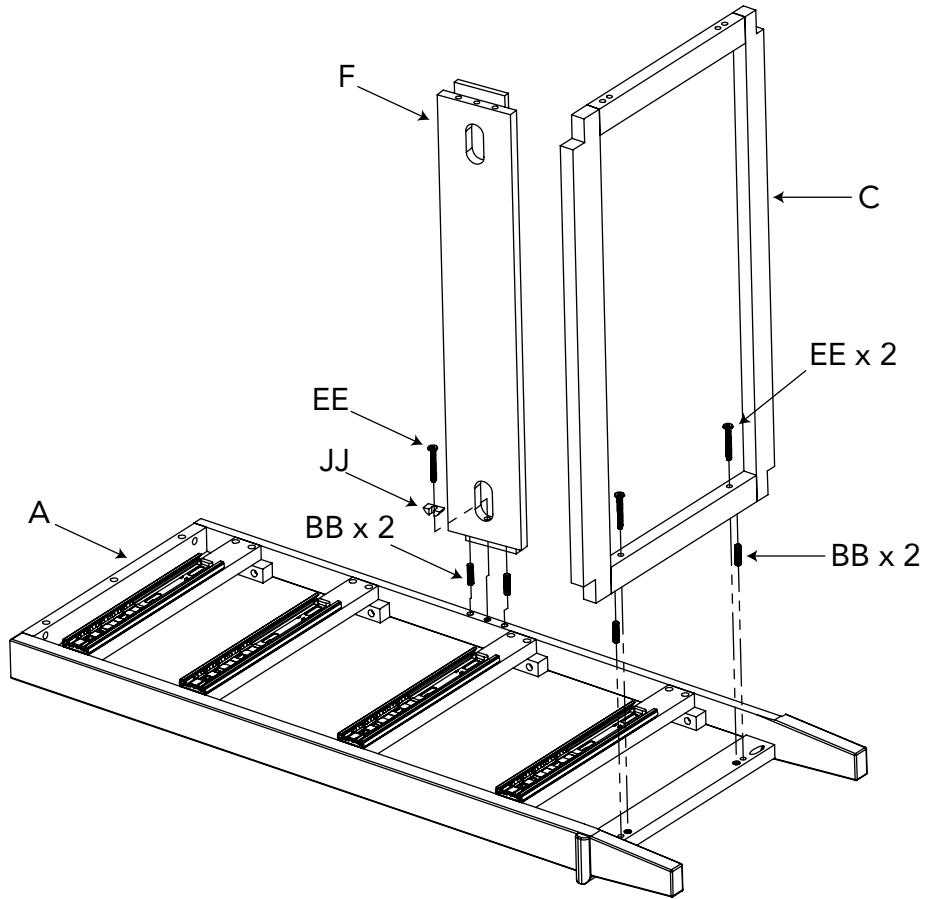

A x 1
C x 1
F x 1
BB x 4
EE x 3
JJ x 1

AB20516\_G4

# STEP 2

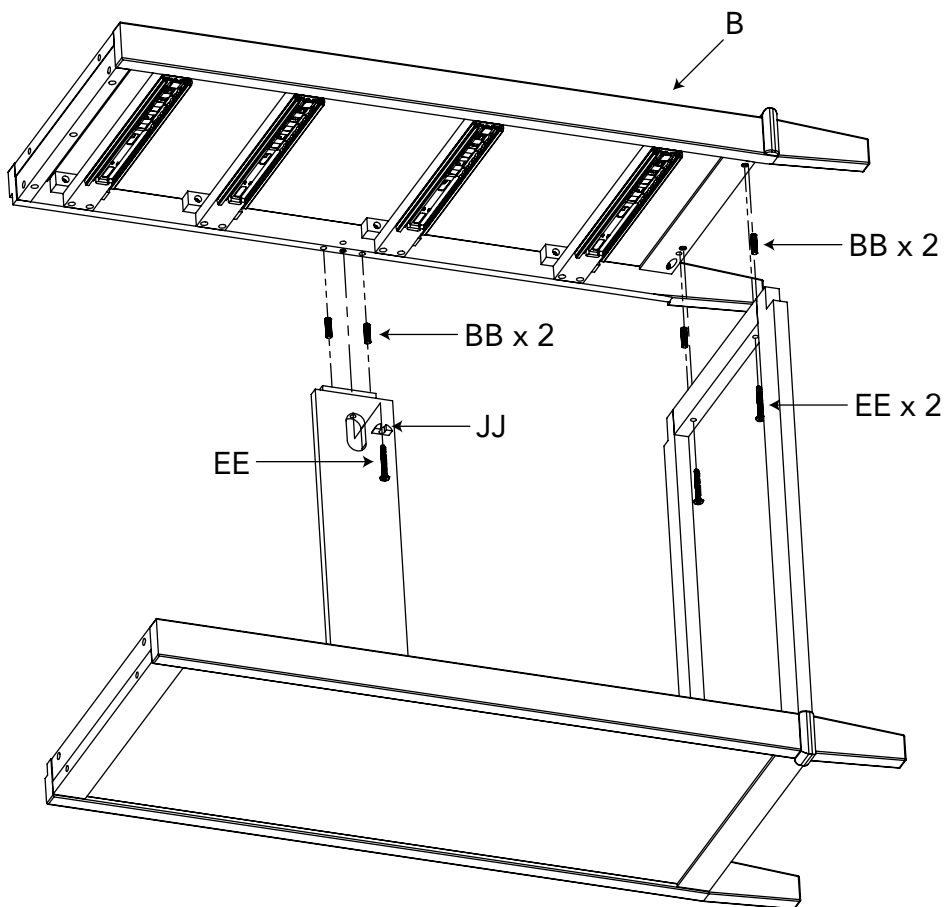

B x 1
BB x 4
EE x 3
JJ x 1

AB20516\_G5

# STEP 3

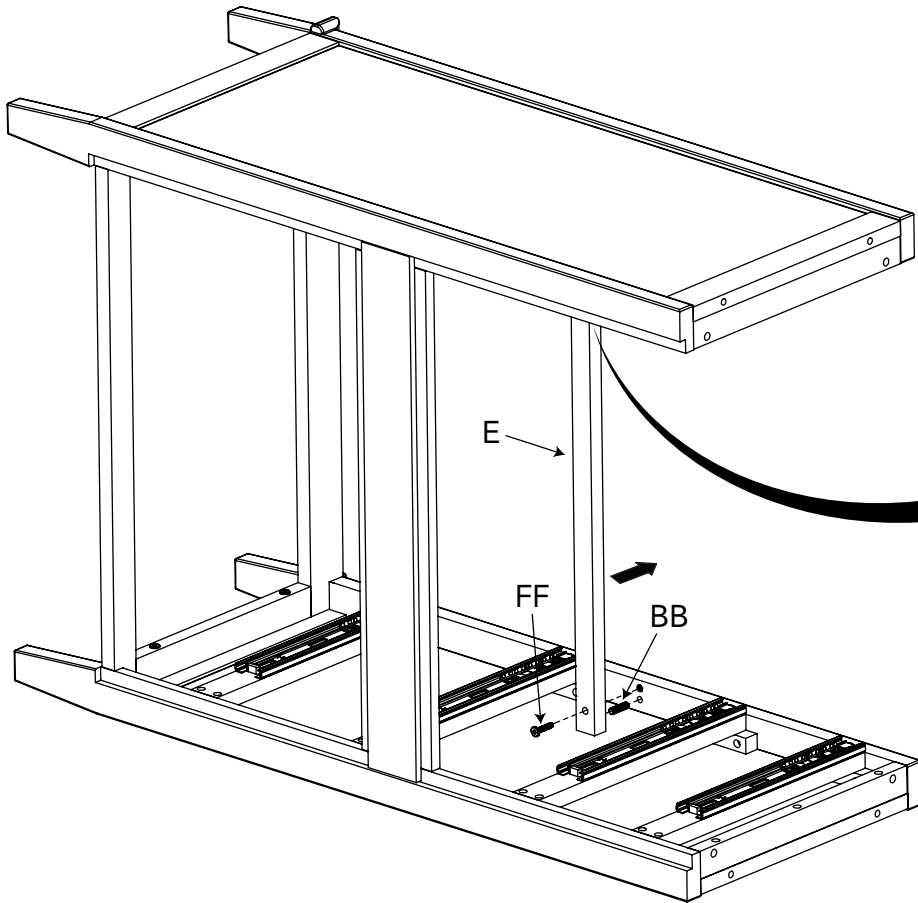

E x 1
BB x 2
FF x 2

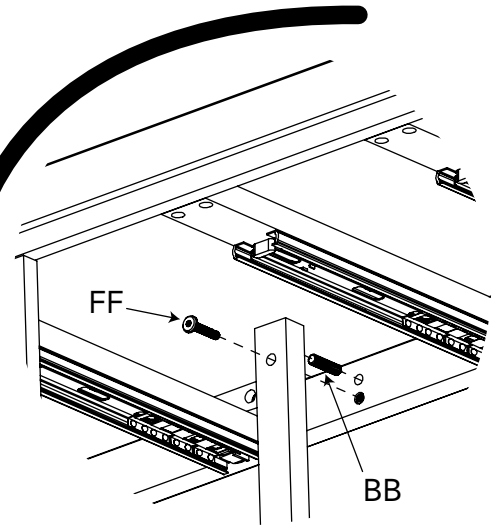

AB20516\_G6

# STEP 4

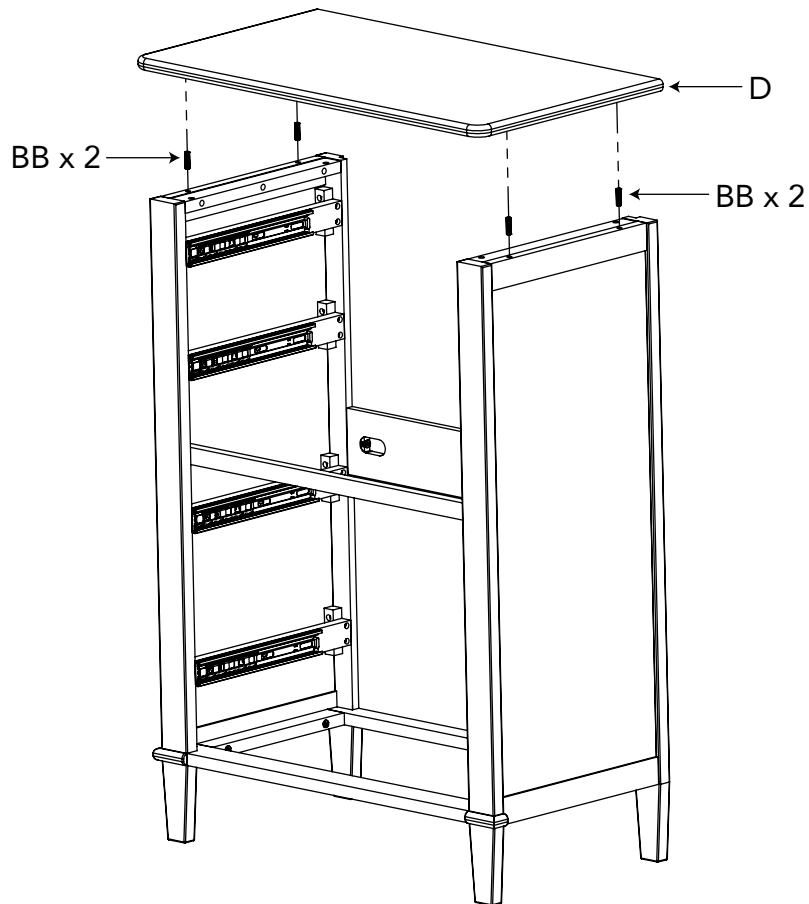

D x 1
BB x 4

AB20516\_G7

# STEP 5

FF x 4

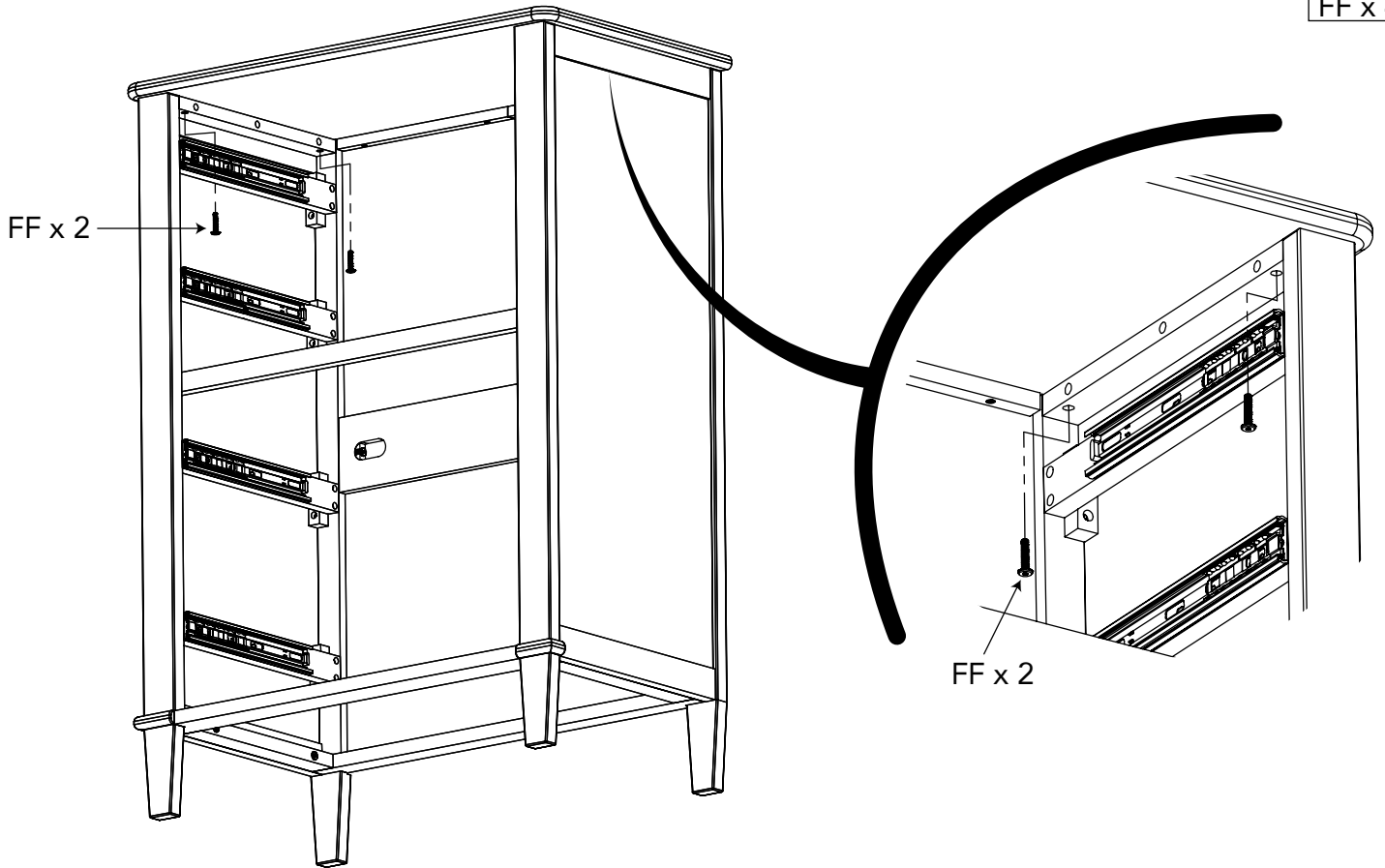

AB20516\_G8

# STEP 6

G x 2  
AA x 28

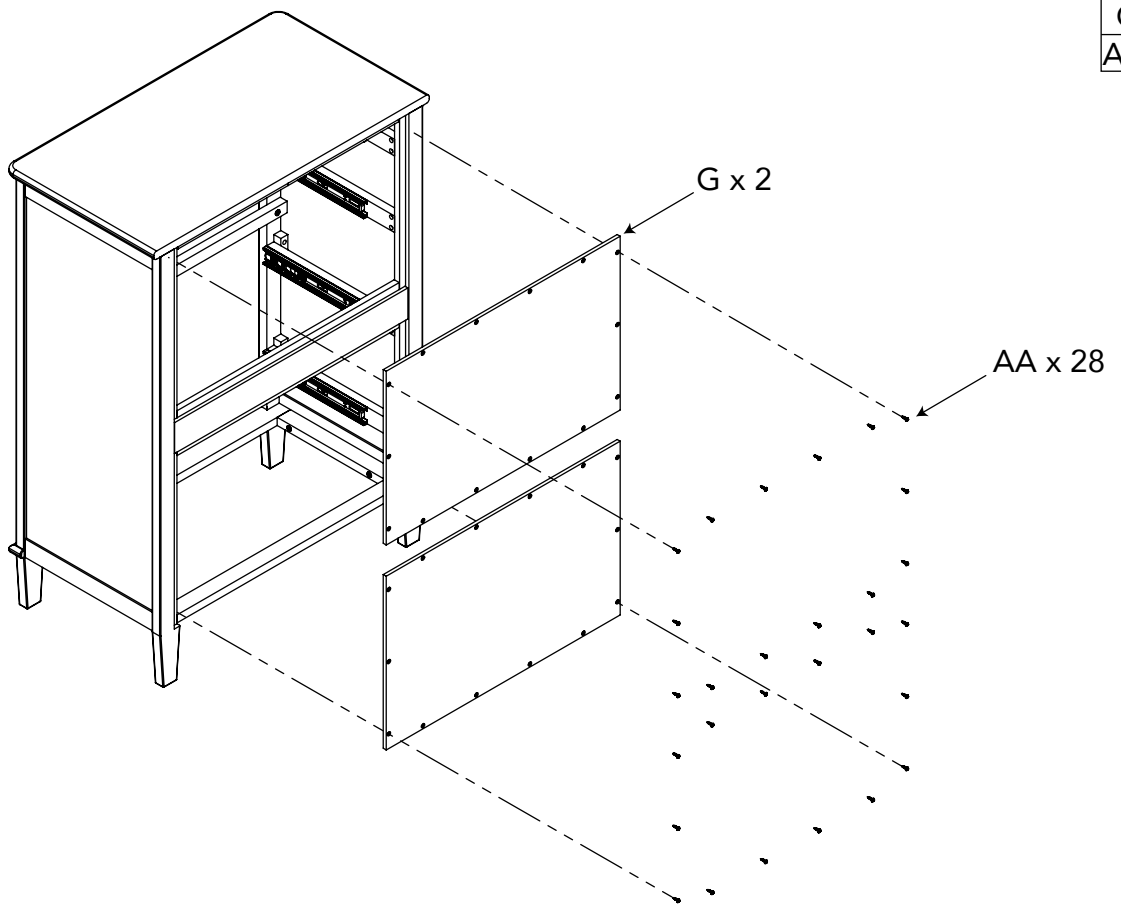

AB20516\_G9

# TOP DRAWER STEP 1

K x 1
L x 1
M x 1
HH x 4

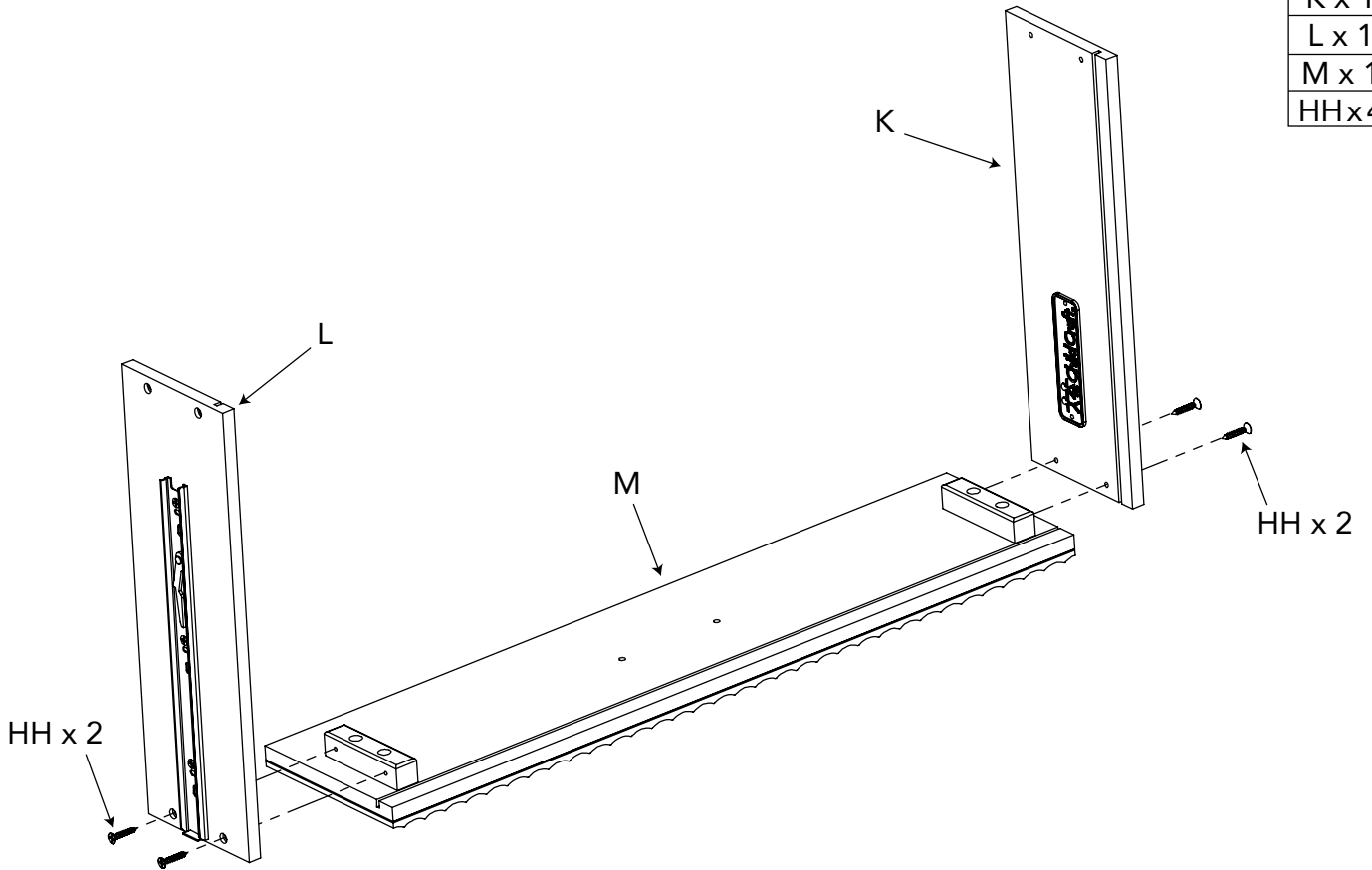

AB20516\_G12

# TOP DRAWER STEP 2

H x 1
I x 1
J x 1
HH x 6

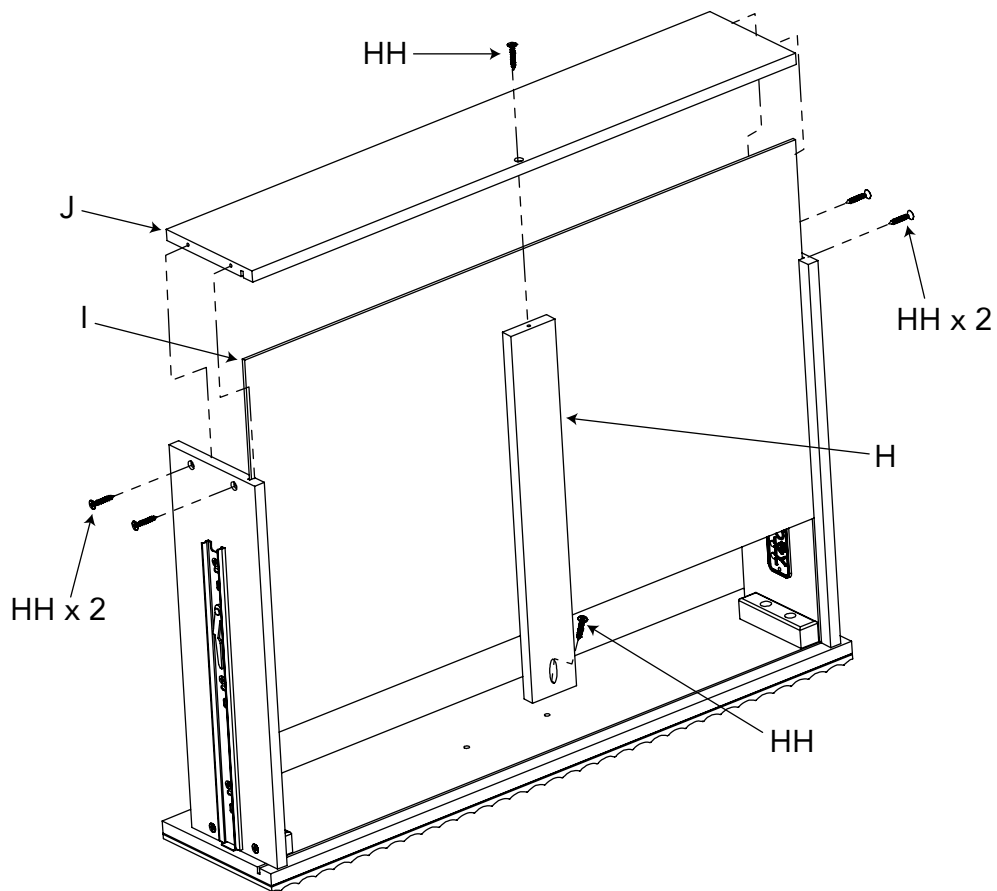

AB20516\_G13

# TOP DRAWER STEP 3

DD x 1
GG x 2

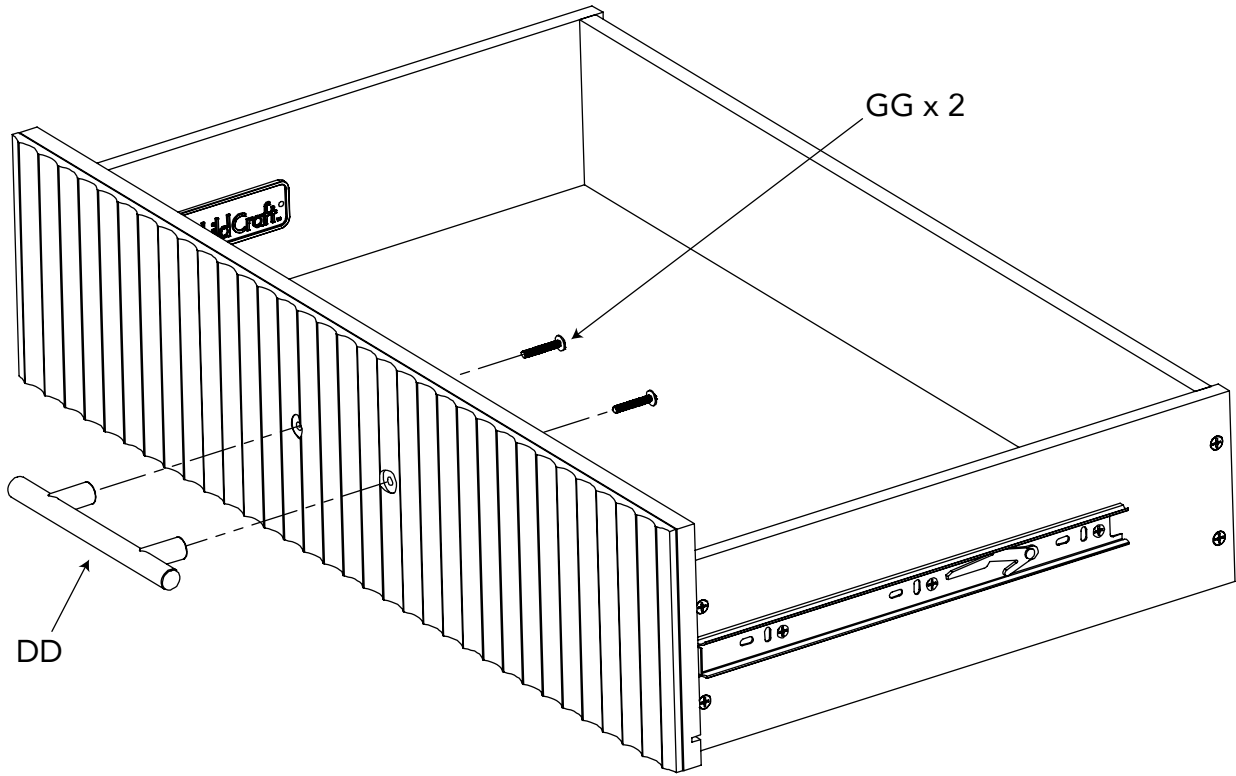

AB20516\_G14

# LOWER DRAWERS STEP 1 (x 3)

N x 1
O x 1
P x 1
HH x 4

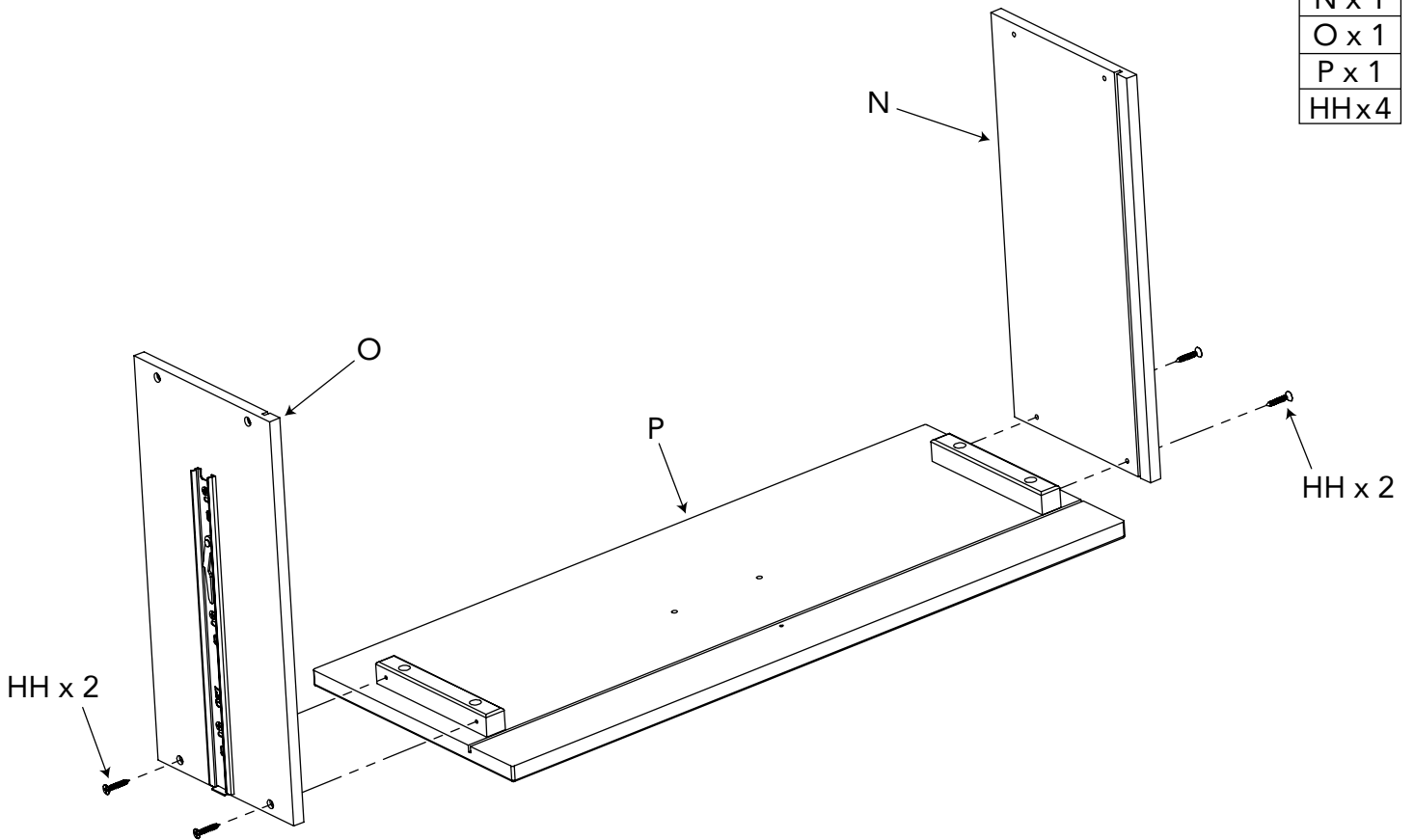

AB20516\_G15



## LOWER DRAWERS STEP 2 (x 3)

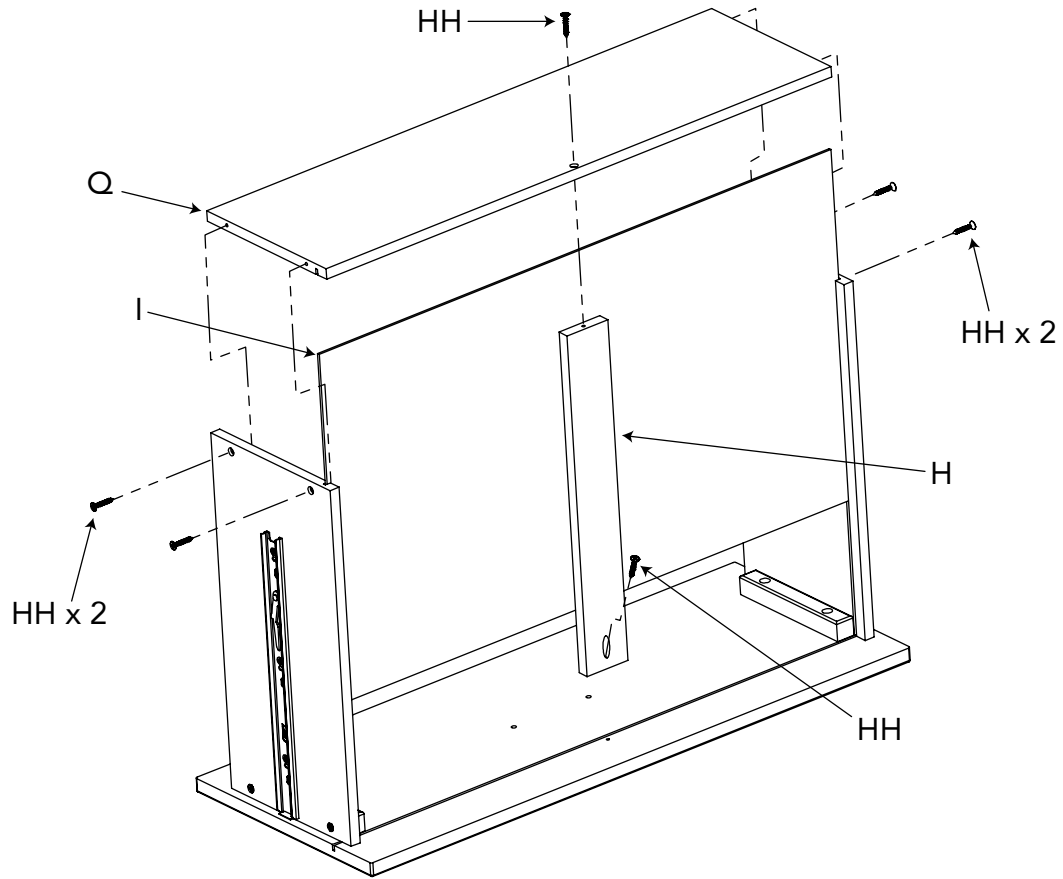

AB20516\_G16

## LOWER DRAWERS STEP 3 (x 3)

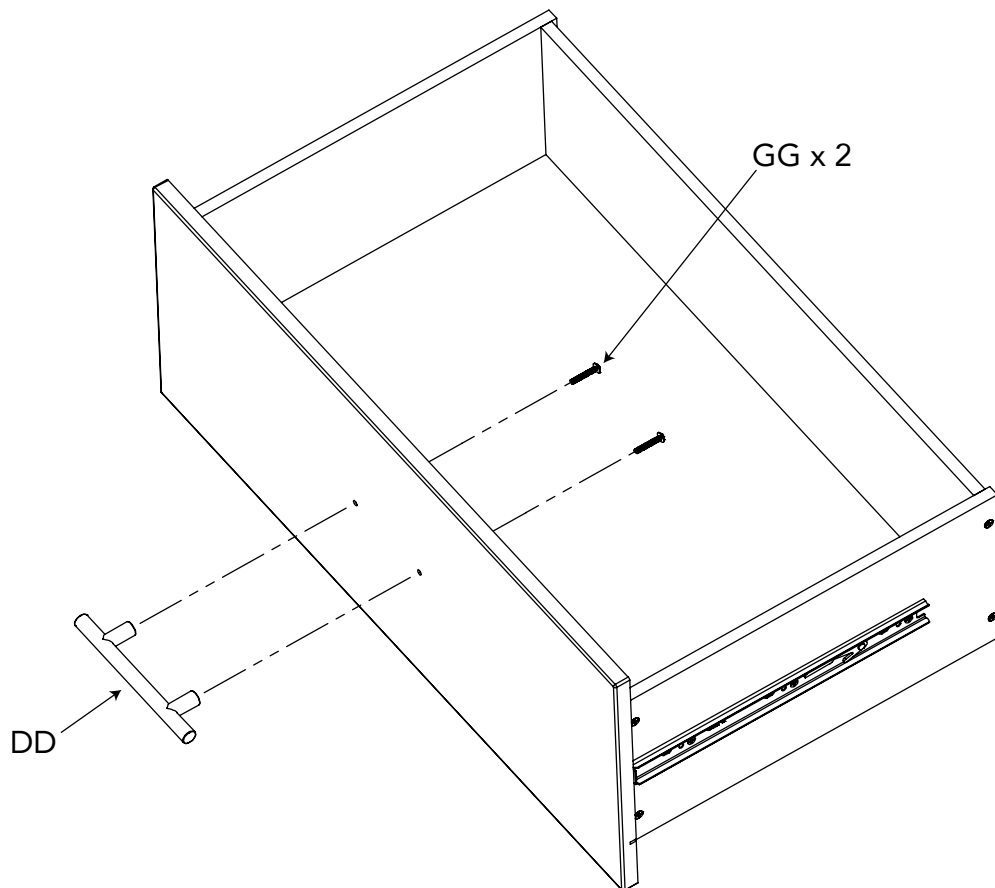

AB20516\_G17

## DRAWER INSTALLATION

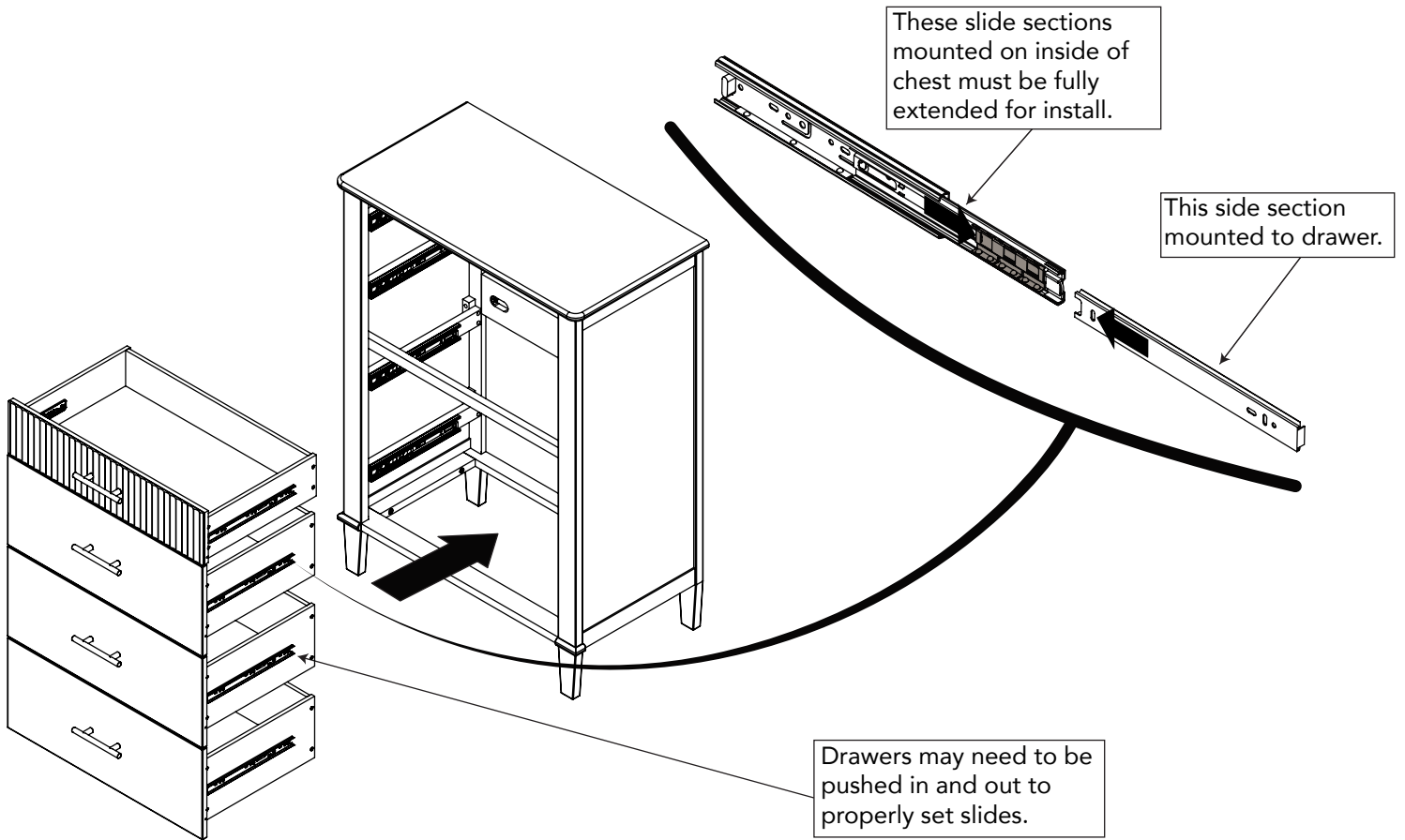

AB20516\_G10

## DRAWER REMOVAL

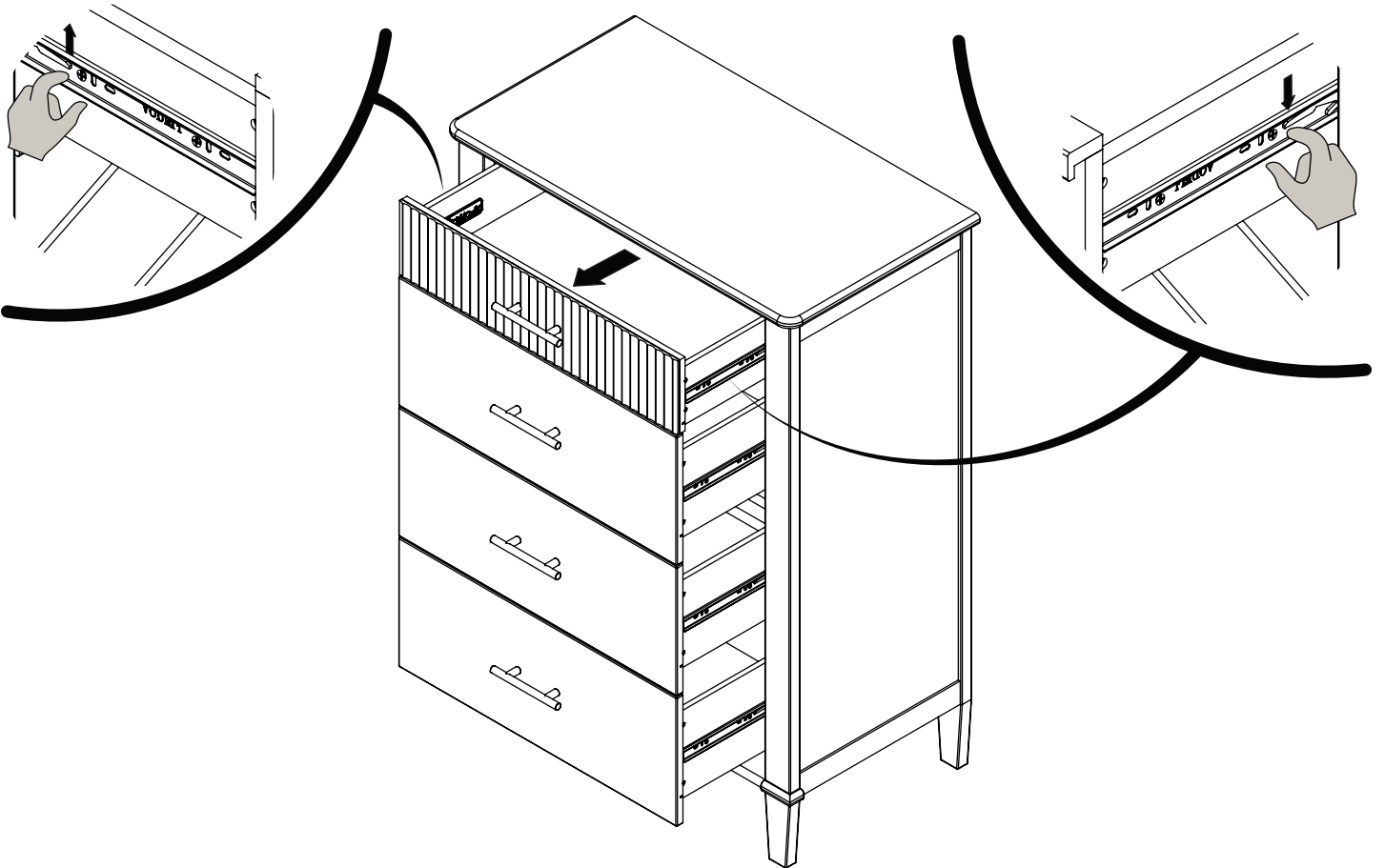

AB20516\_G11

## ANTI TIP KIT ALIGNMENT

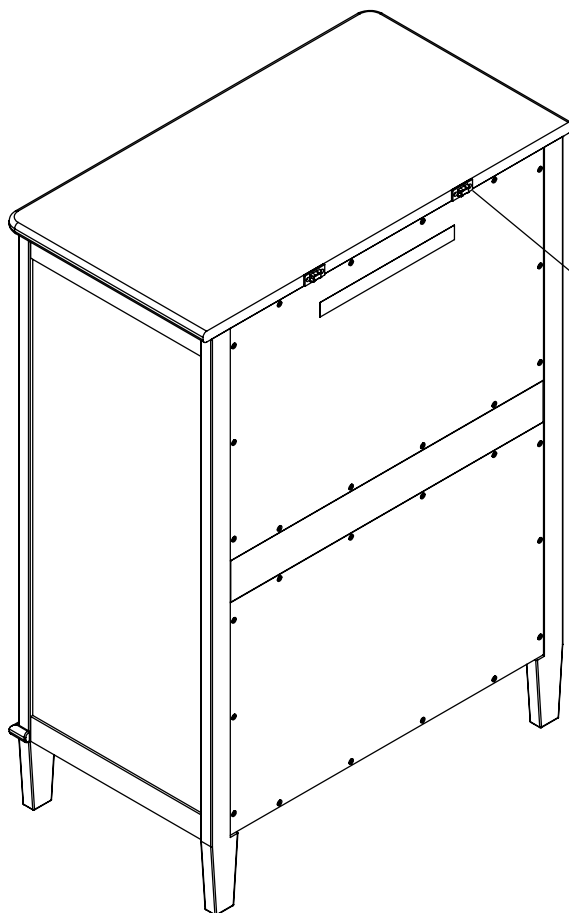

For Anti Tip Kit Installation, top of Anti Tip Bracket should be placed along top edge of the chest.

Please refer to Anti Tip Kit instructions for install.

AB20516\_G18

### **WARNING**

Serious or fatal crushing injuries can occur from furniture tipover. To help prevent tipover:

- Install tipover restraint provided.
- Place heaviest items in the lower drawers.
- Do not set TVs or other heavy objects on the top of this product.
- Never allow children to climb or hang on drawers, doors, or shelves.
- Never open more than one drawer at a time.

Use of tipover restraints may only reduce, but not eliminate, the risk of tipover.

# MAINTENANCE, CLEANING, AND STORAGE

## MAINTENANCE:

Upon completion of the assembly, check to make sure all screws, bolts and connectors are tightened and secure. Periodically check furniture for damaged hardware, loose joints, missing parts or sharp edges before and after assembly and frequently during use.

DO NOT use furniture if any parts are missing or broken.

If any parts are missing, broken or you need assistance DO NOT return furniture to your dealer.

Call Child Craft at 330-723-0599 and include model identification numbers recorded on page 1.

DO NOT substitute parts.

## CLEANING:

Mix a mild solution of gentle dishwashing soap and water, apply to surface using a clean cloth lightly dampened in the solution. Rinse well with clear water using a soft clean cloth, then dry all surfaces with a soft dry cloth.

DO NOT use abrasive cleaners or any cleaners with harsh chemicals that would contact a child's skin, scouring pads, steel wool or coarse rags. This furniture should be treated the same as any fine furniture.

## STORAGE:

When storing furniture use caution as extreme temperature or humidity changes could be harmful.

Use caution when a vaporizer is in use. Always aim vapor stream away from furniture as well as away from any wood furniture item.

**After completing the assembly, the user is advised to read and be aware of ALL WARNINGS, CAUTIONS, CLEANING, STORAGE USE AND MAINTENANCE. Please store the complete set of assembly directions for future referral.**



Shop More for Your  
**Nursery, Toddler,  
Playroom & Beyond**



5216 Portside Dr.  
Medina, Ohio 44256 USA  
Telephone: 330.723.0599  
Fax: 330.722.5037  
www.childcraftbaby.com

IMPORTED BY:  
Foundations Worldwide Inc.  
30 Casebridge Court  
Scarborough, ON M1B 3M5 CAN  
330.722.5033