



CHILD CRAFT INDUSTRIES, INC.

P.O. Box 444, Salem, IN USA 47167-0444

PH: 812-883-3111 - FAX: 812-883-1819 - <http://www.childcraftind.com>

ASSEMBLY DIRECTIONS AND PARTS LIST

Φ **READ ALL INSTRUCTIONS WITH CARE BEFORE STARTING THE ASSEMBLY PROCEDURE.**

Φ **YOU WILL NEED A #2 PHILLIPS SCREWDRIVER, A SLOTTED SCREWDRIVER AND A HAMMER.**

PARTS ENCLOSED IN HARDWARE BAG (NOTED WHEN SHOWN ACTUAL SIZE) DO NOT SUBSTITUTE PARTS!

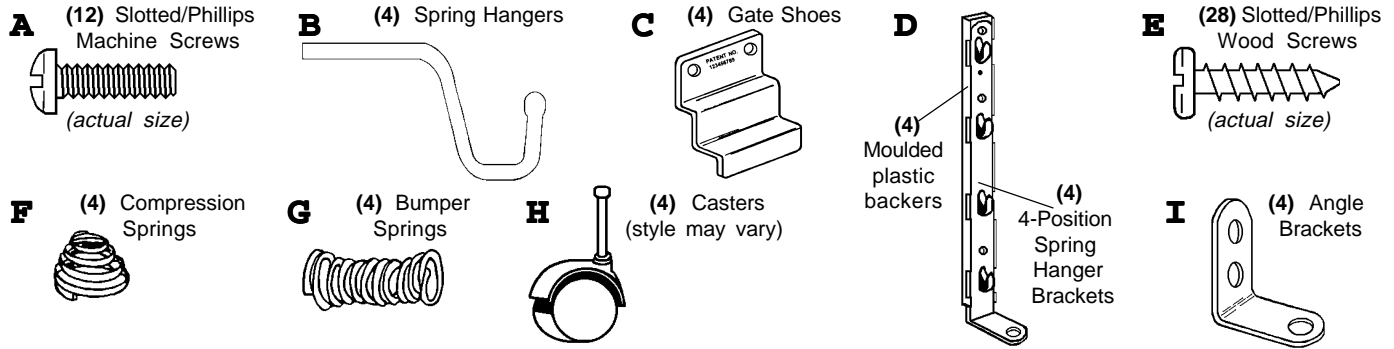

PARTS INCLUDED IN CARTON

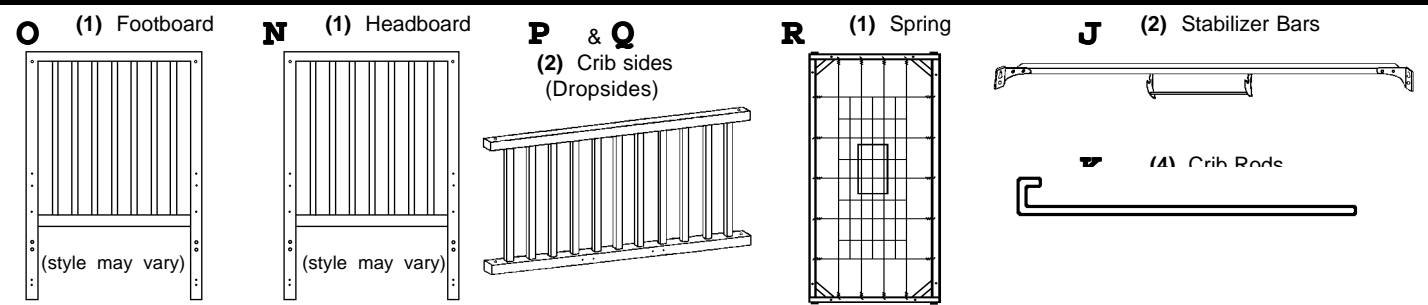

PREPARATION

Carefully remove and lay out all hardware and parts. Remove wires securing the (2) Stabilizer Bars **J** and the (4) Crib Rods **K** to Crib Spring **R**. Check quantities and match to the **Parts Lists** above. If any part is missing or broken contact your dealer or Child Craft (P.O. Box 444, Salem, IN 47167-0444 USA (ph# 812/883-3111), service@childcraftind.com for a replacement part or instructional literature. Before making this contact, identify your crib. A model identification number is stamped on the label attached to the inside face of Footboard **O** bottom rail, or stamped on the underneath side of the bottom rail of either a crib end **N/O** or a crib side **P/Q**. **Record the model Identification Number now: # _____.**

STEP 1 - DIAGRAM 1: ATTACHMENT OF 4-POSITION SPRING HANGER BRACKETS AND ANGLE BRACKETS.

Note the two piece assembly of the 4-Position Spring Hanger Brackets **D**. Before attachment to crib (*ends*), **N/O**, check to be sure the moulded plastic backer is aligned with the 4-Position Spring Hanger Bracket **D** as shown in **Diagram**. These items are shipped assembled, in the unlikely event they should become detached during shipment, simply take the plastic backer and align with the holes in the metal bracket and snap together to create an assembly as shown in **Hardware Parts Diagram & Diagram 1**. **IMPORTANT!** All four plastic tabs on each moulded plastic backer should project toward the metal hooks on 4-Position Spring Hanger Brackets **D**. If you should find a tab not so projected simply use a screwdriver to push tab forward until it contacts the metal hook. Attach the 4-Position Spring Hanger Brackets **D**, (2 piece assembly), to both Headboard **N** & Footboard **O** with Slotted/Phillips Wood Screws **E**, to be positioned exactly as shown in **Diagram 1**. Attach two Angle Brackets **I** to Headboard **N** and two Angle Brackets **I** to Footboard **O** using Slotted/Phillips Wood Screws **E**, refer to **Diagram 1** for exact positioning. **DO NOT REMOVE 4-POSITION SPRING HANGER BRACKETS D, ANGLE BRACKETS I, OR ANY OTHER HARDWARE ITEM ATTACHED WITH SLOTTED/PHILLIPS WOOD SCREWS E.**

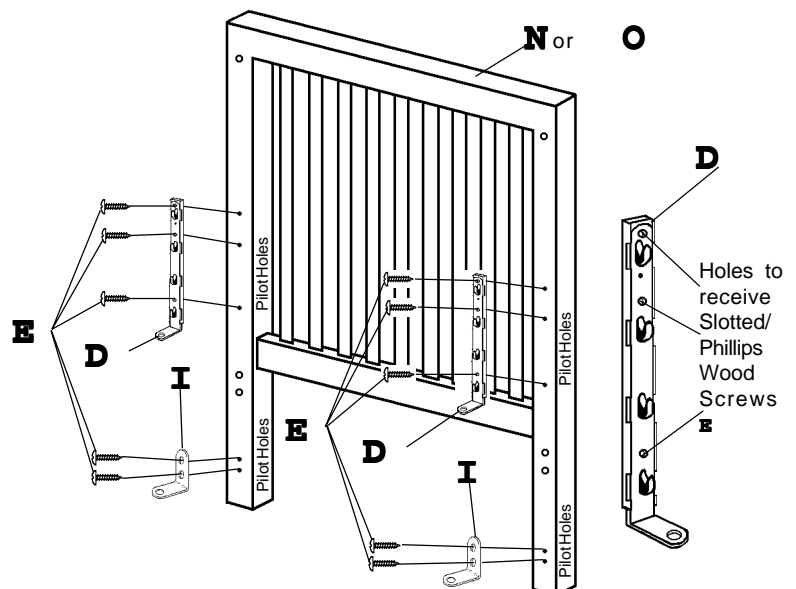

STEP 2 - DIAGRAM 2: INSTALL STABILIZER BARS.

Attach each Stabilizer Bar **J** to crib ends **N** and **O**. Refer to **Diagrams 2** and **MAIN DIAGRAM 6**. (You will use a total of **(8)** Slotted/Phillips Machine Screws **A**. Place a Slotted/Phillips Machine Screw **A** into top receiving bushing, designated for Stabilizer Bar **J** placement, located in ends **O** & **N** shown in **Diagram**, leave each top screw extended - **do not tighten at this time**, refer to **Diagram 2**. Place the keyhole (top hole in each end of Stabilizer Bar **J**), over top extended Slotted/Phillips Machine Screws **A** (which you have just installed and left extended), refer to **Diagram 2** and **MAIN DIAGRAM 6**, Ends **N** and **O** will now be mounted together on one side of crib, repeat this procedure for mounting the remaining Stabilizer Bar **J** to the other side of the crib in the exact same manner. Place four **(4)** remaining Slotted/Phillips Machine Screws **A** into the lower receiving holes in each end of both Stabilizer Bars **J**, into receiving bushings located in ends **N** & **O**, tighten all eight **(8)** Slotted/Phillips Machine Screws **A** securely at this time.

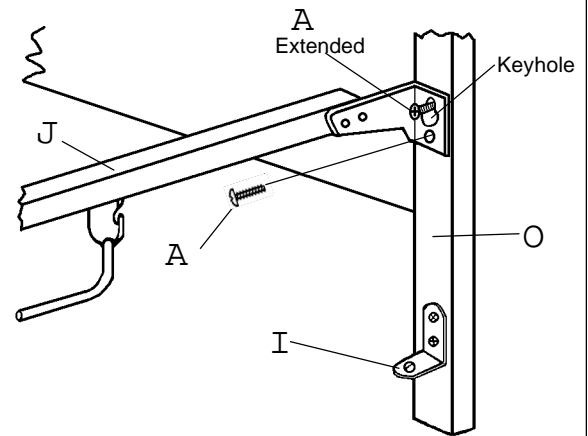

STEP 3 - DIAGRAM 3: ATTACH GATE SHOES TO DROPSIDES.

Position two Gate Shoes **C** to lower rail (inside) of each Crib Side **P** / **Q** as shown in **Diagram**. **Note:** Gate Shoe Patent Number will be visible when Gate Shoes **C** are mounted. Align Gate Shoes **C** over predrilled lead holes (lower rail (inside) of Crib Side **P/Q** (dropsides) and affix with **(8)** Slotted/Phillips Wood Screws **E**, (two in each Gate Shoe **C**). Tighten Slotted/Phillips Wood Screws **E** securely. **Note:** When disassembling crib in the future, **DO NOT REMOVE THE GATE SHOES OR ANY OTHER HARDWARE ITEM ATTACHED WITH SLOTTED/PHILLIPS WOOD SCREWS E**.

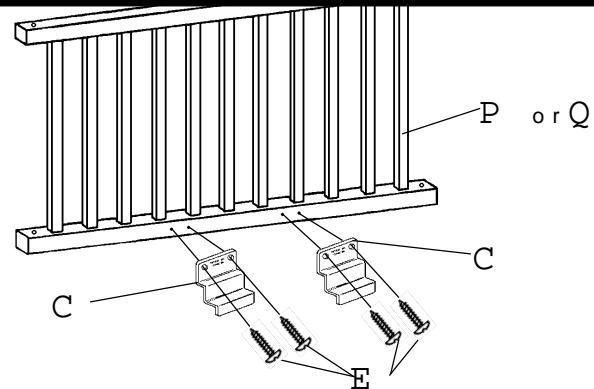

STEP 4 - DIAGRAM 4: INSTALL SPRING HANGERS & CRIB SPRING

Locate Crib Spring **R**, (with plastic pouch factory attached), and the four Spring Hangers **B**, refer to **Main Diagram 6**, and **4**. **Note:** Be sure smooth side of Crib Spring **R** wire is placed upward as illustrated in **Main Diagram 6**. Also the printing on the plastic pouch (attached to crib spring) will be placed upward. Insert Spring Hangers **B** into each bracket attached to frame of Crib Spring **R** as shown, (a light blow with a hammer may be required to fully engage Spring Hangers **B**). Carefully install Crib Spring **R** by placing each of the 4 Spring Hanger **B** into a selected position in each of the four 4-Position Spring Hanger Brackets **D**, (with moulded plastic backers), mounted on ends **O** and **N**. See **Main Diagram 6**, and **4**. **Note:** The lip of the moulded plastic backer will allow the Spring Hanger to be placed with no difficulty. However, when you decide on another placement of Crib Spring **R** you will need to place your thumbnail, or a small screwdriver, on the lip of the moulded plastic backer and hold down in order to raise Spring Hanger **B** from its present position. Follow this same procedure whenever you decide to change Crib Spring **R** to another of the four positions.

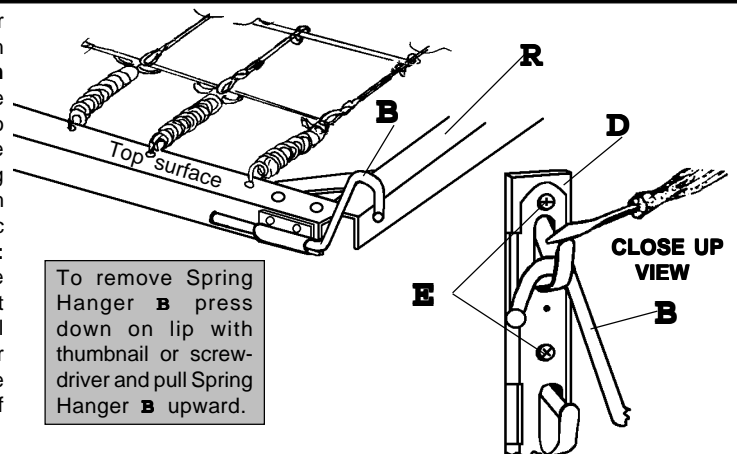

STEP 5: INSTALL CRIB DROPSIDES

Locate Crib Rods **K**, Crib Sides **P/Q**, Compression Springs **F**, Bumper Springs **G** and the four remaining Slotted/Phillips Machine Screws **A**. Insert a Crib Rod **K** downward through the holes in the following sequence: (Refer to **Main Diagram 6** for proper placement.)

1. The top rail of Crib Side **P** or **Q**, (with plastic teething rail), (Note: gate shoes will be placed to inside),
2. The L- bracket on 4-Position Spring Hanger Bracket **D**,
3. Compression Spring **F**,
4. Bottom Rail of Crib Side **P** or **Q**,
5. A Bumper Spring **G**,
6. Hole in Angle Bracket **I**.

Place a Slotted/Phillips Machine Screw **A** into hole in top of Crib Rod **K** and into receiving bushing located in top corner post of Footboard **O** / Headboard **N**. Refer to **Main Diagram 6** for proper placement. **DO NOT USE A POWER SCREWDRIVER OF ANY TYPE TO TIGHTEN SCREW A**. Start Screw **A** (two or three turns) with your fingers into its threaded bushing to insure Screw **A** has a square fit. Once you are sure Screw **A** fits squarely into its threaded bushing, tighten securely with a hand held screwdriver. Attach the other Crib Rod **K** to the other end of Crib Side **P** or **Q**, using the same procedure. Be sure Slotted/Phillips Machine Screws **A** are tightened securely, check periodically and tighten if needed. **Tip:** To help Crib Rods **K** function quietly we suggest you rub the crib rod with waxed paper or paraffin. You may want to repeat this procedure periodically. Attach the remaining Crib Side **P** or **Q**, by repeating **Step 5**.

MAIN DIAGRAM 6

TIGHTEN SCREW A MANUALLY, DO NOT USE ANY TYPE OF POWER SCREWDRIVER.

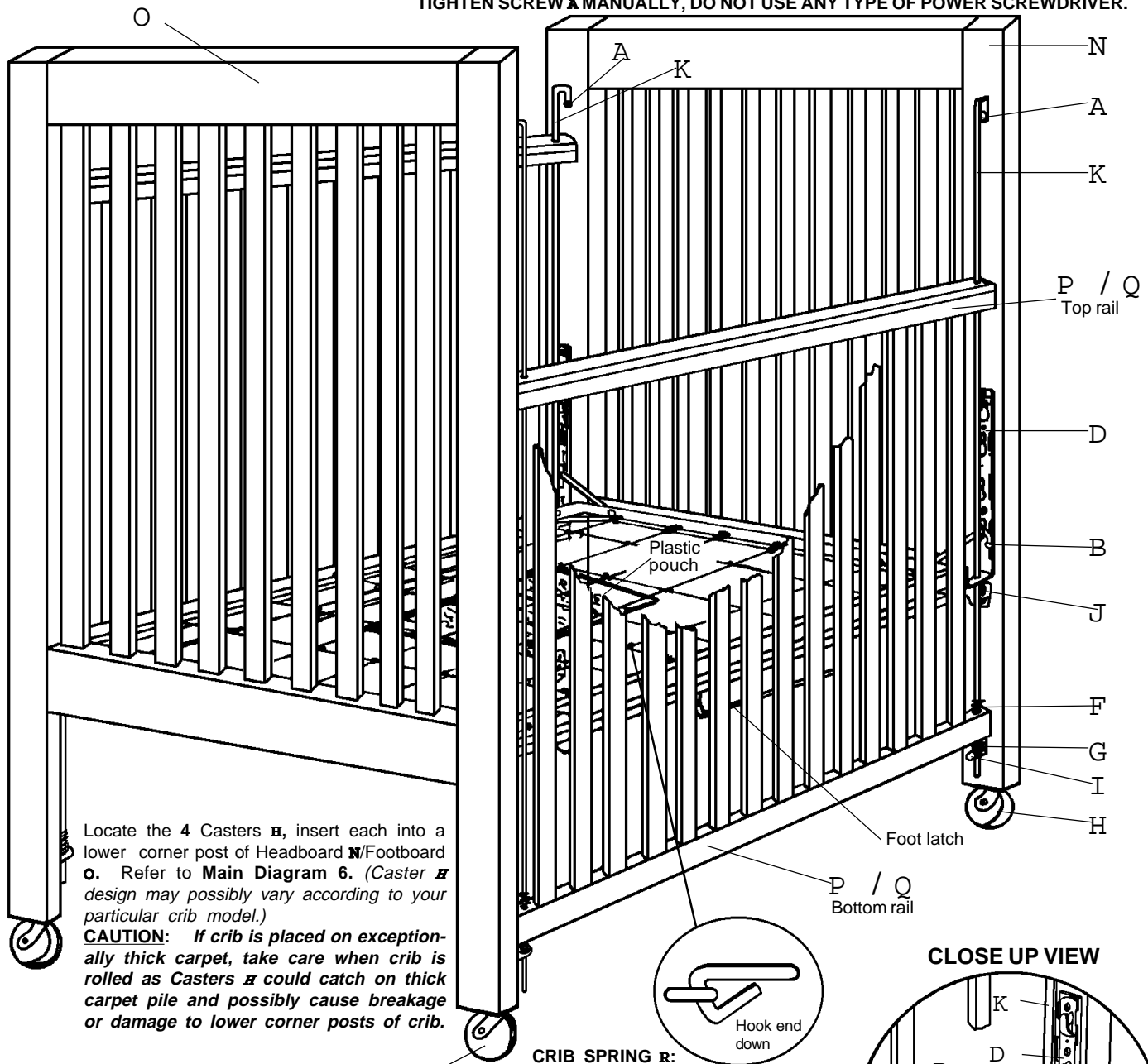

Locate the 4 Casters **H**, insert each into a lower corner post of Headboard **N**/Footboard **O**. Refer to **Main Diagram 6**. (Caster **H** design may possibly vary according to your particular crib model.)

CAUTION: If crib is placed on exceptionally thick carpet, take care when crib is rolled as Casters **H** could catch on thick carpet pile and possibly cause breakage or damage to lower corner posts of crib.

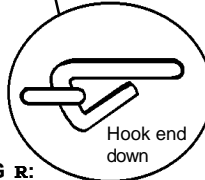

CRIB SPRING R: Be sure the smooth side of wire is placed up as illustrated. Also, style of Crib Spring **R** may differ with your model of crib.

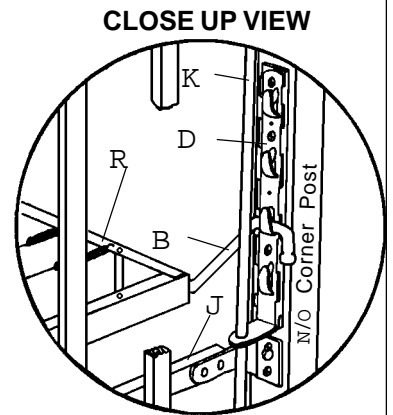

Permanent Storage of Assembly Instructions: After completing the assembly process you are advised to read and be aware of all **WARNINGS, CAUTIONS, CLEANING, STORAGE, USE, and MAINTENANCE** notices contained in this set of assembly directions and printed on the plastic pouch located on the underneath side of crib spring. You will then place this complete set of assembly directions into the plastic pouch for future referral. We caution you not to place excess hardware in the plastic pouch as it could present danger to a small child if retrieved.

Place a purchased mattress on Crib Spring **R** and crib is ready for use.

TO RAISE & LOWER CRIB DROPSIDE: To lower lift the dropside slightly, push the foot latch toward the inside of crib which will release the dropside to the lowest or "DOWN" position. To raise the dropside, lift up on the dropside, rail will then lock into the "UP" position.



! WARNING

CCH00713:09/00

⊕ FAILURE TO FOLLOW THESE WARNINGS AND ASSEMBLY INSTRUCTIONS COULD RESULT IN SERIOUS INJURY OR DEATH.

⊕ READ ALL INSTRUCTIONS BEFORE ASSEMBLING CRIB. KEEP INSTRUCTIONS FOR FUTURE USE. A plastic pouch is attached to crib spring for permanent storage of the instructional literature.

⊕ BEFORE EACH USAGE OR ASSEMBLY, INSPECT CRIB FOR DAMAGED HARDWARE, LOOSE JOINTS, MISSING PARTS OR SHARP EDGES. DO NOT USE CRIB IF ANY PARTS ARE MISSING OR BROKEN. ASK YOUR DEALER OR CHILD CRAFT, P.O. BOX 444, SALEM, IN 47167-0444 USA (812/883-3111) service@childcraftind.com FOR REPLACEMENT PARTS AND INSTRUCTIONAL LITERATURE IF NEEDED. INCLUDE MODEL IDENTIFICATION NUMBERS WITH YOUR REQUEST WHICH YOU RECORDED ON PAGE ONE. DO NOT SUBSTITUTE PARTS.

⊕ AFTER RAISING SIDE, MAKE SURE LATCHES ARE SECURE.

⊕ WHEN CHILD IS ABLE TO CLIMB OUT OR REACHES THE HEIGHT OF 35 INCHES (90 CENTIMETERS) THE CRIB SHALL NO LONGER BE USED.

⊕ DO NOT PLACE CRIB NEAR WINDOW WHERE CORDS FROM BLINDS OR DRAPES MAY STRANGLE A CHILD.

⊕ IF REFINISHING, USE A NON-TOXIC FINISH SPECIFIED FOR CHILDREN'S PRODUCTS.

⊕ DO NOT LEAVE CHILD IN CRIB WITH SIDE LOWERED. BE SURE SIDE IS IN RAISED AND LOCKED POSITION WHENEVER CHILD IS IN CRIB.

⊕ WHEN CHILD IS ABLE TO PULL TO STANDING POSITION, SET MATTRESS TO LOWEST POSITION AND REMOVE BUMPER PADS, LARGE TOYS AND OTHER OBJECTS THAT COULD SERVE AS STEPS FOR CLIMBING OUT.

⊕ NEVER USE PLASTIC SHIPPING BAGS OR OTHER PLASTIC FILM AS MATTRESS COVERS BECAUSE THEY CAN CAUSE SUFFOCATION.

⊕ DO NOT USE A WATER MATTRESS WITH THIS CRIB.

⊕ REPLACE TEETHING RAIL(S) IF DAMAGED OR LOOSE.
(if equipped with teething rails)

⊕ STRINGS CAN CAUSE STRANGULATION! DO NOT PLACE ITEMS WITH A STRING AROUND A CHILD'S NECK, SUCH AS HOOD STRINGS OR PACIFIER CORDS. DO NOT SUSPEND STRINGS OVER A CRIB OR ATTACH STRINGS TO TOYS.

⊕ REMOVE ALL CRIB TOYS WHICH ARE STRUNG ACROSS CRIB AREA WHEN YOUR CHILD IS BEGINNING TO PUSH UP ON HANDS AND KNEES OR IS 5 MONTHS OF AGE, WHICHEVER OCCURS EARLIEST. THESE TOYS CAN CAUSE STRANGULATION!

⊕ WHEN DISASSEMBLING THIS CRIB, DO NOT REMOVE ANY ITEM ATTACHED WITH WOOD SCREWS.

⊕ ALWAYS ENSURE A SAFE ENVIRONMENT FOR THE CHILD BY CHECKING REGULARLY, BEFORE PLACING THE CHILD IN THE CRIB, THAT EVERY COMPONENT IS PROPERLY AND SECURELY IN PLACE.

CAUTION

⊕ ANY MATTRESS USED IN THIS CRIB MUST BE AT LEAST 27-1/4 INCHES (69 CENTIMETERS), BY 51-5/8 INCHES (131 CENTIMETERS), WITH A THICKNESS NOT EXCEEDING 6 INCHES (15 CENTIMETERS). THE DIMENSIONS OF THE MATTRESS SHALL BE TAKEN FROM SEAM TO SEAM OR EDGE TO EDGE WHERE APPROPRIATE.

⊕ UPON COMPLETION OF ASSEMBLY BE SURE ALL SCREWS, BOLTS AND FASTENING DEVICES HAVE BEEN TIGHTENED SECURELY. A FREQUENT CHECK SHOULD BE MADE OF ALL SCREWS, BOLTS AND FASTENING DEVICES AND TIGHTEN IF NEEDED.

MAINTENANCE OF YOUR CHILD CRAFT CRIB: Upon completion of assembly be sure all screws, bolts and fastening devices have been tightened securely. A frequent periodic check should be made of all screws, bolts and fastening devices and tighten if needed. Before each usage or assembly, inspect crib for damaged hardware, loose joints, missing parts or sharp edges. **DO NOT** use crib if parts are missing or broken. Ask your Dealer or Child Craft (812/883-3111), service@childcraftind.com for replacement parts and instructional literature if needed. Include Model Identification Number with your request which you recorded on page 1. **DO NOT** substitute parts. **DO NOT** make any alteration to this crib.

CLEANING INSTRUCTIONS FOR YOUR CHILD CRAFT CRIB: Mix together a mild solution of gentle dishwashing liquid and water, apply to crib surface using a soft clean cloth lightly dampened in the solution. Rinse with clear water again using a soft clean cloth then dry all surfaces thoroughly with a soft dry cloth. **NO ABRASIVE CLEANERS, SCOURING PADS, STEEL WOOL, OR COARSE RAGS SHOULD BE USED TO CLEAN THIS FINE FURNITURE.**

STORAGE AND USE OF YOUR CHILD CRAFT CRIB: A printed plastic pouch is attached to the crib spring for the permanent storage of the assembly directions. After completing the assembly process you are advised to read and be aware of all WARNINGS, CAUTIONS, CLEANING, STORAGE, USE AND MAINTENANCE notices contained in this set of assembly directions and printed on the plastic pouch located on the underneath side of crib spring. You will then place the complete set of assembly directions into the plastic pouch for future referral. We caution you not to place excess hardware in the plastic pouch as it could present danger to a child if retrieved and it could also puncture crib mattress. When storing crib use CAUTION as extreme temperature or humidity changes could be harmful. Use CAUTION when a vaporizer is in use, always aim vaporstream away from crib as well as away from any other wood furniture item.

CCH00713:09/00 JCHE p65

made in usa

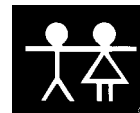

CHILD CRAFT INDUSTRIES, INC.

P.O. Box 444, Salem, IN USA 47167-0444

PH: 812-883-3111 - FAX: 812-883-1819

<http://www.childcraftind.com>