

Thomas Crib











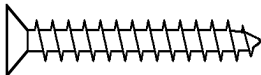
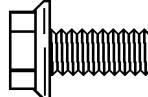

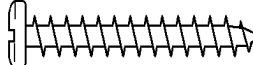
pottery barn kids

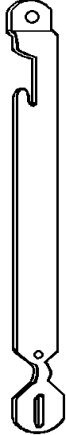
**SINGLE DROPSIDE CRIB  
(CONVERTS TO TODDLER  
BED w/MODEL 11714)**

ASSEMBLY DIRECTIONS AND PARTS LIST

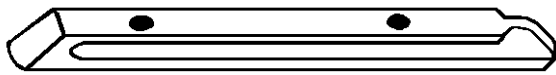
Φ READ ALL INSTRUCTIONS WITH CARE BEFORE STARTING THE ASSEMBLY PROCEDURE.  
Φ YOU WILL NEED A PHILLIPS SCREWDRIVER, A STANDARD SLOTTED SCREWDRIVER, A 3/8" & 7/16" WRENCH (or adjustable wrench), AND THE ENCLOSED ALLEN WRENCH **κ** & HEXHEAD WRENCH **σ**.

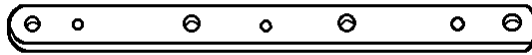
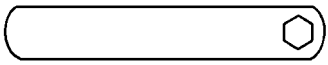
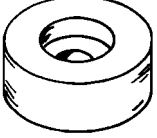
**PARTS ENCLOSED IN HARDWARE BAG (NOTED WHEN SHOWN ACTUAL SIZE)**

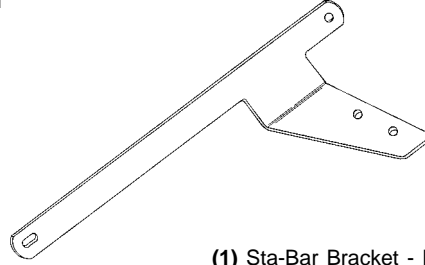
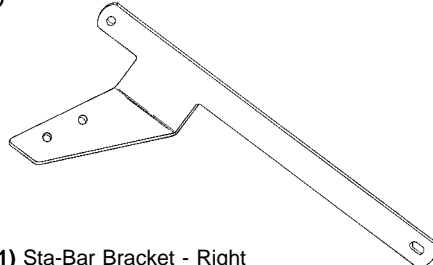
<p><b>A</b> (4) F/H Phillips Wood Screw</p>  <p>(actual size)</p>	<p><b>B</b> (4) Hexhead Machine Screw</p>  <p>(actual size)</p>	<p><b>D</b> (4) Phillips Pan Head Machine Screw</p>  <p>(actual size)</p>	<p><b>E</b> (16) Combo Pan Head Wood Screw</p>  <p>(actual size)</p>	<p><b>L</b> (4) K-D Bolt Plugs</p>  <p>(actual size)</p>
<p><b>F</b> (1) Lower Track Assembly (Right)</p> 	<p><b>G</b> (1) Lower Track Assembly (Left)</p> 	<p><b>H</b> (4) Allenhead K-D Bolts</p>  <p>(actual size)</p>		<p><b>I</b> (4) Insert Locknut</p>  <p>(actual size)</p>
		<p><b>J</b> (2) Upper Tracks</p> 	<p><b>K</b> (1) Allen Wrench</p> 	
		<p><b>P</b> (4) 4-Position Spring Bracket</p> 	<p><b>S</b> (1) Hexhead Wrench</p> 	
<p><b>Q</b> (2) Rubber Washers</p>  <p>(actual size)</p>	<p><b>R</b> (2) Combo Machine Screw</p>  <p>(actual size)</p>	<p><b>N</b></p>  <p>(1) Sta-Bar Bracket - Left</p>		<p><b>O</b></p>  <p>(1) Sta-Bar Bracket - Right</p>

**PREPARATION**

Carefully remove and lay out all hardware and parts. Check quantities and match the Hardware List and the Parts List. **NOTE: During the assembly process whenever using screws or bolts, check each with the Hardware List by letter and size identification. Place each screw or bolt on the diagram of the item which is sketched actual size. Be sure to use the proper size specified in the assembly directions.** If a part is missing or broken contact Pottery Barn Kids or write to Child Craft Industries, Inc., P.O. Box 444, Salem, IN 47167 USA for replacement part(s) or instructional literature. Before making this contact identify your Crib by the model identification number stamped on a label attached to the inside face of Footboard bottom rail. Make note of all identification numbers and include this information with your request.

**DO NOT SUBSTITUTE PARTS!**

Record your model identification number here for future identification: **Model #** \_\_\_\_\_

**PARTS ENCLOSED IN CARTON**

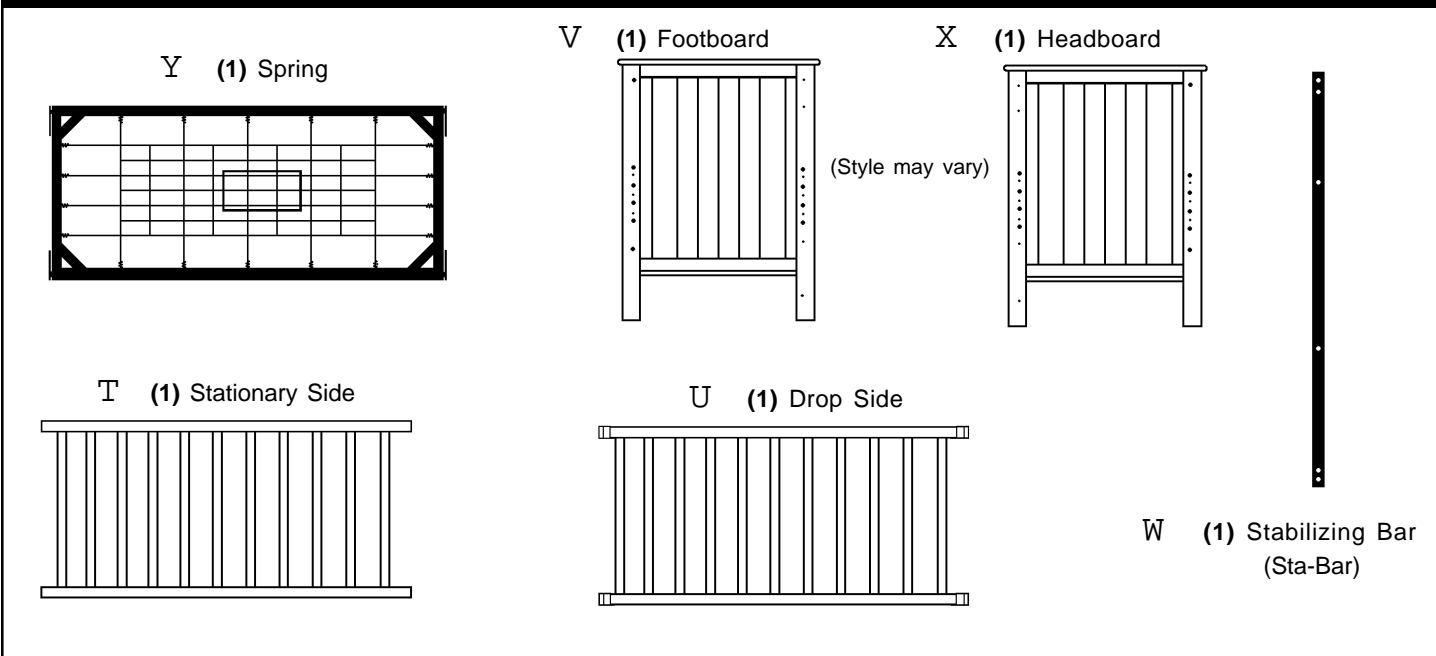

**STEP 1 - DIAGRAM 1: ATTACH HARDWARE TO FOOTBOARD AND HEADBOARD**

*(HELPFUL HINT: Hardware installation may be easier if the Footboard V and Headboard X*

*are placed in a horizontal position on a soft surface being careful not to scratch the crib finish).* Install Upper Track J to the Footboard V and the Headboard X using two F/H Phillips Wood Screws A as shown. Attach 4-position Spring Brackets P using three Combo Pan Head Wood Screws E as shown. Mount Lower Track Assembly Right F to Footboard V. Start by installing a Combo Pan Head Wood Screw into the holes on Lower Track Assembly Right F, through the holes in Sta-Bar Bracket - Right O, and into the pilot holes in Footboard Corner Post V. Tighten securely. Follow the same procedure to attach Lower Track Assembly Left G and Sta-Bar Bracket Left N to Headboard Corner Post X. **NOTE: Open slot at top of Lower Track assembly F & G faces the inside of your crib. Install hardware exactly as illustrated.**

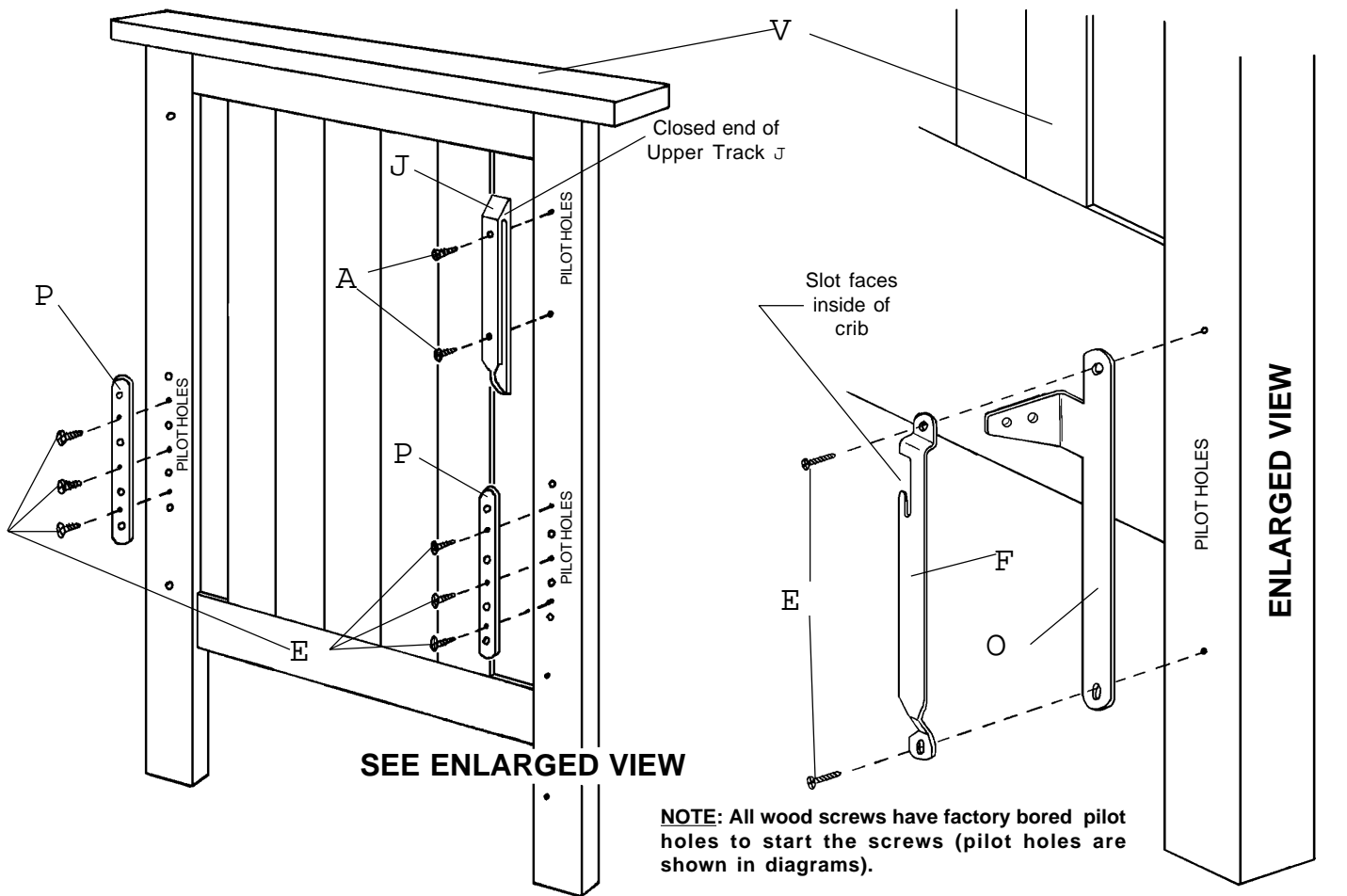

**STEP 2 - DIAGRAM 2: ATTACH STABILIZING BAR TO HEADBOARD AND FOOTBOARD**

Mount the Stabilizing Bar Assembly **W** to Footboard **V** and Headboard **X**. With the Footboard **V** in a vertical position, insert (2) Phillips Pan Head Machine Screws **D** through the holes in Sta-Bar Bracket - Right **O**, and through the holes in Stabilizing Bar **W**. Attach (2) Insert Locknuts **I** to Machine Screws **D** and tighten securely. **See Enlarged View for the proper installation of Locknut I.** Follow the same procedure for attaching Stabilizing Bar **W** to Headboard **X**.

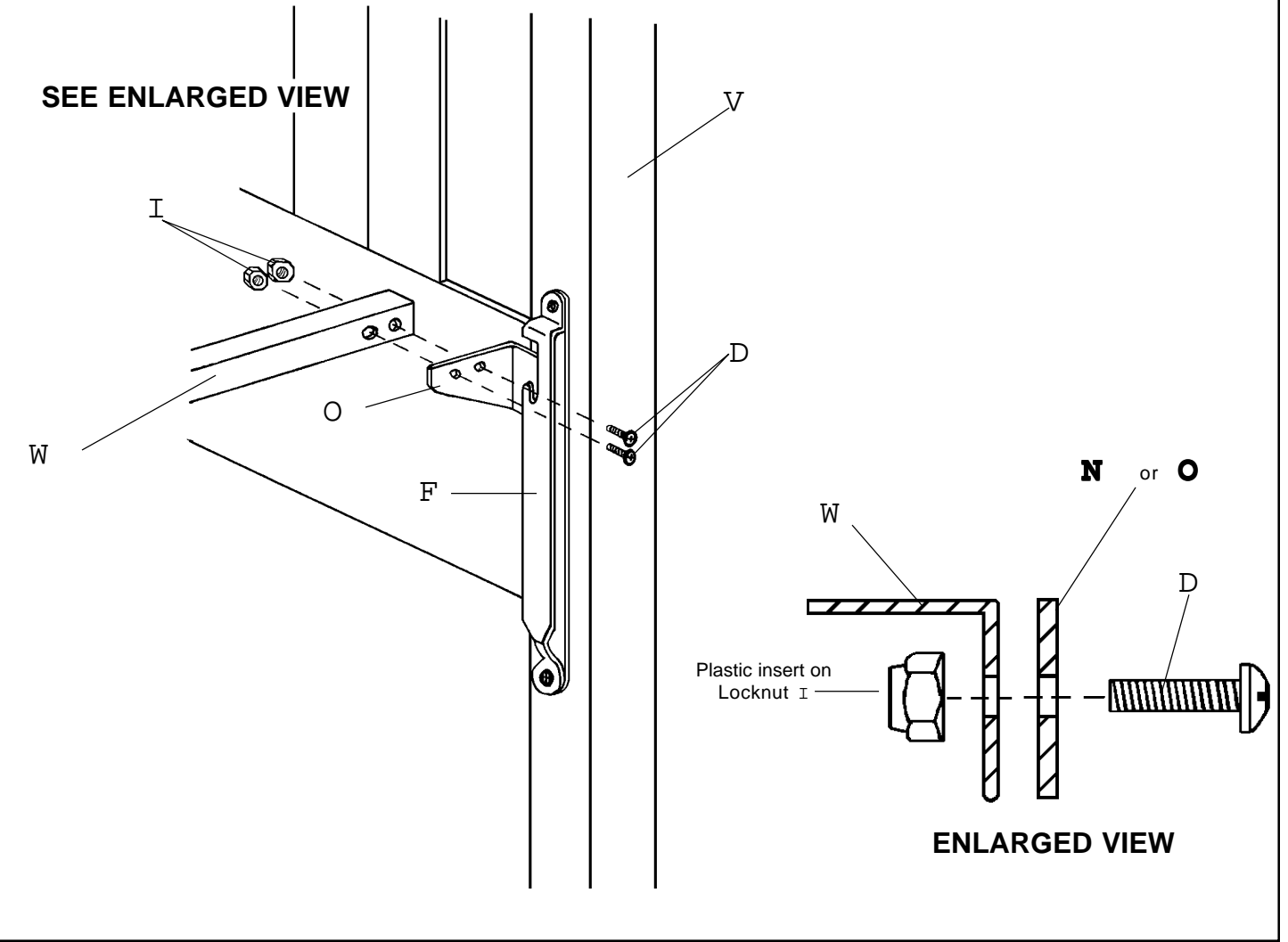

**STEP 3 - DIAGRAM 3: ATTACH STATIONARY SIDE**

Attach Stationary Side **T** to Headboard **X** & Footboard **V**. Insert each of the four Allenhead K-D Bolts **H** into receiving holes located in corner posts of crib ends **V** & **X** as shown. Place Stationary Side **T** in alignment and allow K-D Bolts **H** to continue into ends of top and bottom rails of Stationary Side **T**. Insert each of the four K-D Bolt Plugs **L** as shown. Pull out each K-D Bolt **H** just enough to allow the K-D Bolt Plug **L** to be fully inserted in hole. Tighten all four K-D Bolts **H** until secure using Allen Wrench **K** while securing K-D Bolt Plugs **L** with a Standard Slotted Screwdriver. **CAUTION: DO NOT OVERTIGHTEN.**

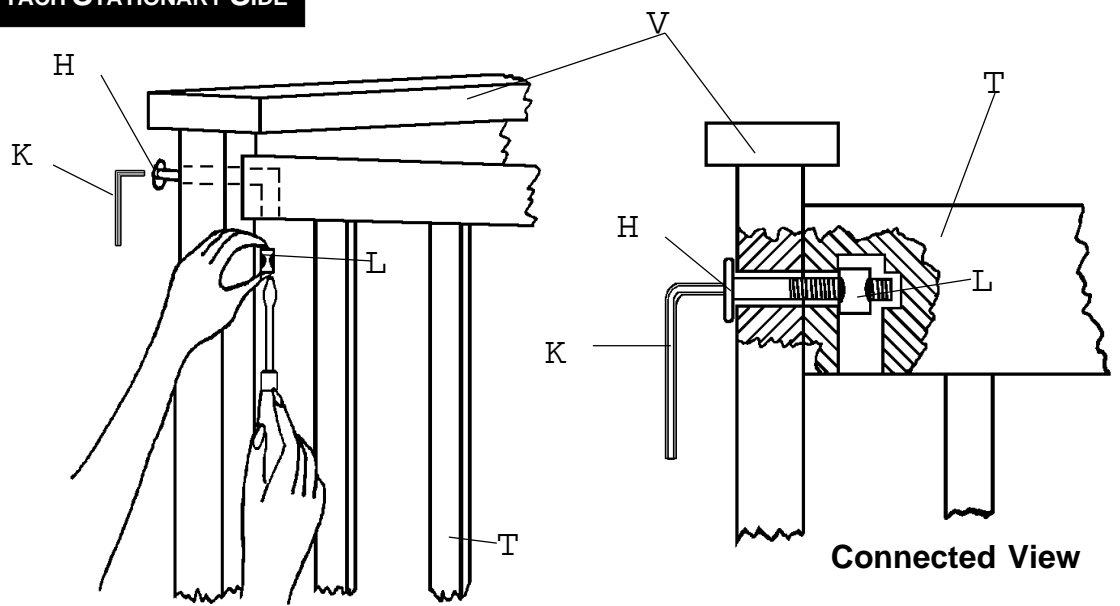

**STEP 4 - DIAGRAM 4: INSTALL SPRING**

Locate "Tabs" on Crib Spring **Y** and rotate Tabs upward to the approximate angle shown. Lower Spring **Y** into crib being careful not to damage the crib finish. Position the (4) Tabs attached to ends of Crib Spring **Y** to mount to a selected position in the 4-Position Spring Brackets **P** mounted on ends **V** and **X**. Install a Hexhead Machine Screw **B** through the (4) Crib Spring Tabs and into a receiving hole in each 4-Position Spring Bracket **P** then tighten securely using Hexhead Wrench **S** or a 3/8" wrench. Follow the same procedure when changing spring height at a later date. Check Hexhead Machine Screws **B** periodically and tighten if needed.

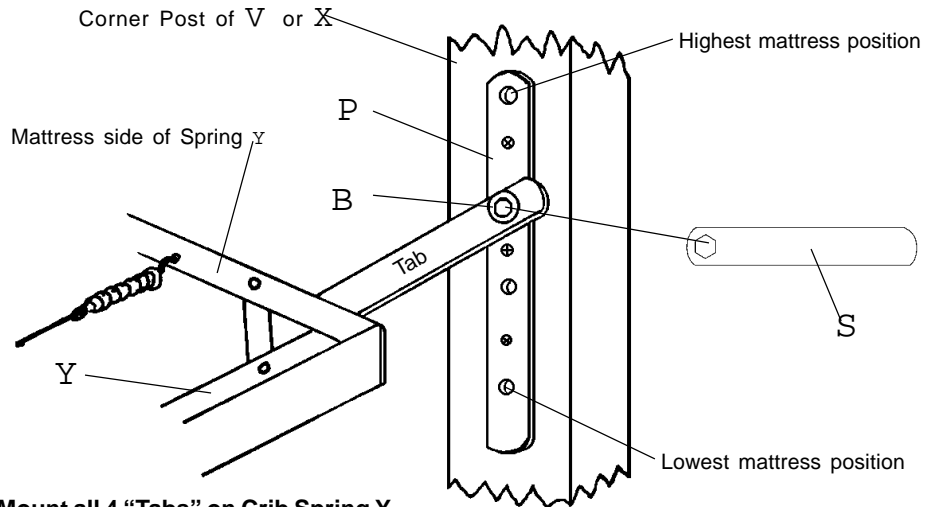

**NOTE: Mount all 4 "Tabs" on Crib Spring **Y** at the same vertical mattress position.**

**STEP 5 - DIAGRAM 5: INSTALL DROPSIDE AND CASTERS**

Align Plastic Guides (Factory installed) on Dropside **U** with dropside hardware mounted on post from underneath. An assistant is very helpful. After all four plastic guides are aligned with the hardware, lift Dropside "UP" and allow it to latch into the raised position.

After Dropside **U** is installed on the tracks and is latched in the "UP" position, insert a Combo Machine Screw **R** into a Rubber Washer **Q** and thread into hole in bottom of Lower Track Assemblies **F** & **G**.

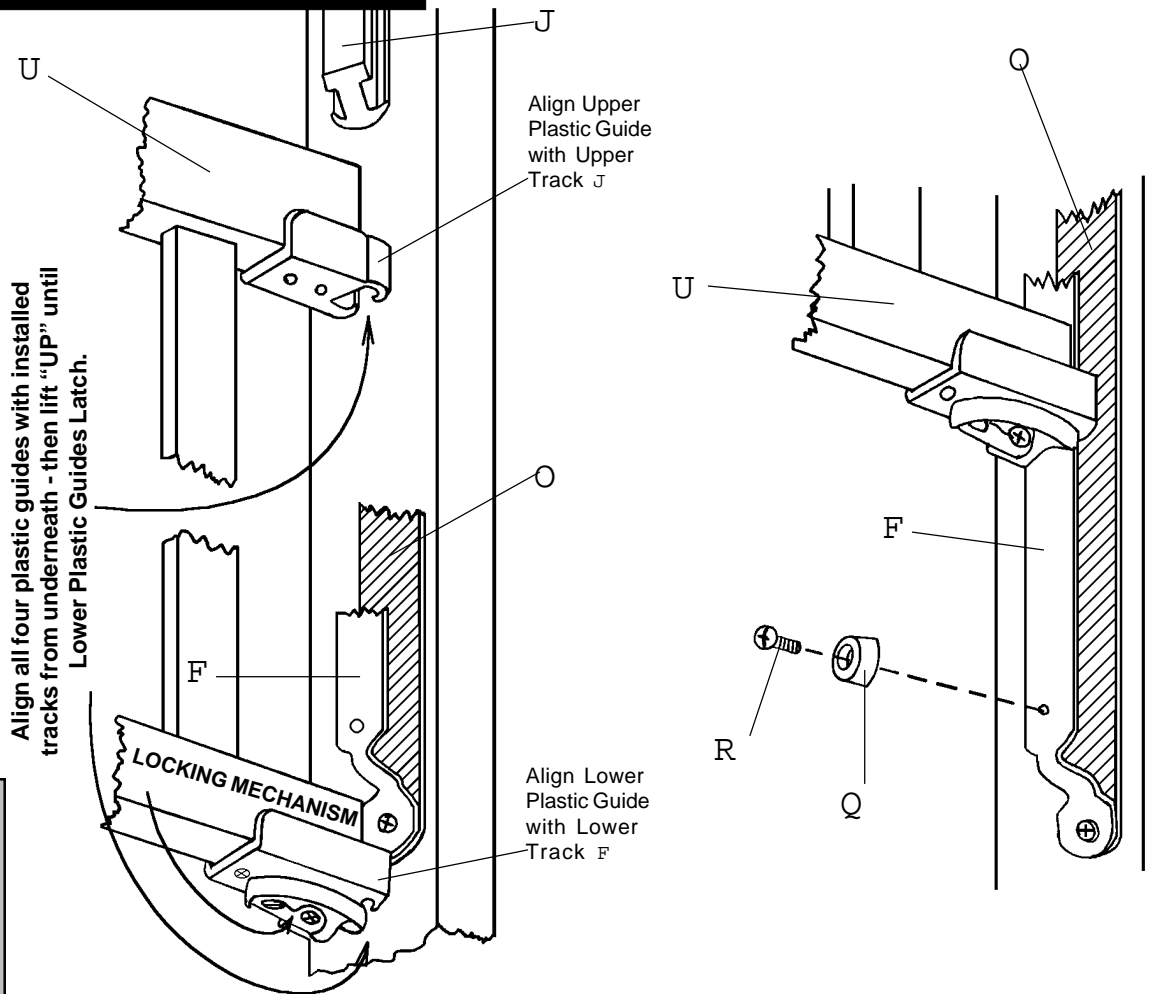



**TO LOWER DROPSIDE **U**: FIRST - LIFT THE DROPSIDE, SECOND - WITH KNEE PUSH IN ON CENTER OF BOTTOM RAIL OF DROPSIDE TO RELEASE LATCH ON LOWER PLASTIC LATCH. LOWER DROPSIDE BY HAND. TO RAISE DROPSIDE **U**: PULL "UP" UNTIL LOWER PLASTIC GUIDES LATCH IN SLOT IN LOWER TRACKS **F** & **G**.**

**NOTE: It may be necessary to Flex the Locking Mechanism toward outside of crib to engage the Lower Tracks **F** & **G**.**

**ALWAYS BE SURE CRIB SIDE IS "UP" AND "LATCHED" BEFORE LEAVING CHILD IN CRIB.**

## DIRECTIONS FOR CONVERTING "CRIB" TO A "TODDLER BED"

When use as a crib has been completed you have the option to convert to a Toddler Bed for years of additional use in your child's room. This requires the purchase of Model 11714. To remove the Dropside, refer to **Step 5 - Diagram 5** and follow directions in reverse order. Follow the directions included with Model 11714 to complete the conversion. **FOR YOUR CHILD'S SAFETY, DO NOT CONVERT THE CRIB TO A TODDLER BED WITHOUT THE PARTS INCLUDED IN MODEL 11714.** Store the removed parts and hardware in the event you wish to convert your daybed back to a crib. Refer to **Sketch A**.

**WHENEVER DISASSEMBLING YOUR CRIB, DO NOT REMOVE ANY ITEMS ATTACHED WITH WOOD SCREWS  OR **

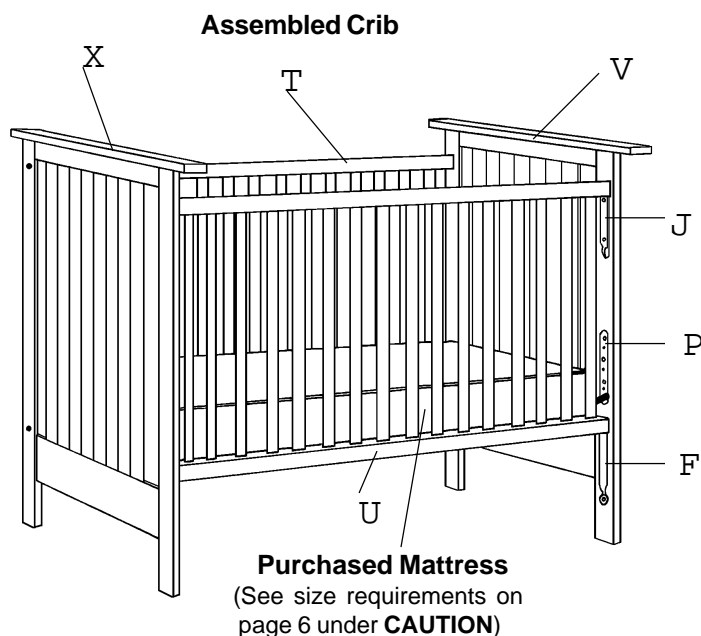

## **WARNING**

**CONVERSION RAIL MODEL 11714 MUST BE USED IF THE CRIB IS CONVERTED TO A TODDLER BED.**

**WHEN USING AS A TODDLER BED, THE MINIMUM AGE SHALL NOT BE LESS THAN 15 MONTHS AND THE MAXIMUM WEIGHT SHALL NOT BE GREATER THAN 50 lb. (22.7 kg).**

**NOTE: WHEN USING AS A TODDLER BED THE MATTRESS MUST HAVE MINIMUM DIMENSIONS OF 51-5/8 IN (1310 mm) IN LENGTH AND 27-1/4 IN (690 mm) IN WIDTH AND 4 IN (100 mm) IN THICKNESS BUT NOT TO EXCEED 6 IN.**

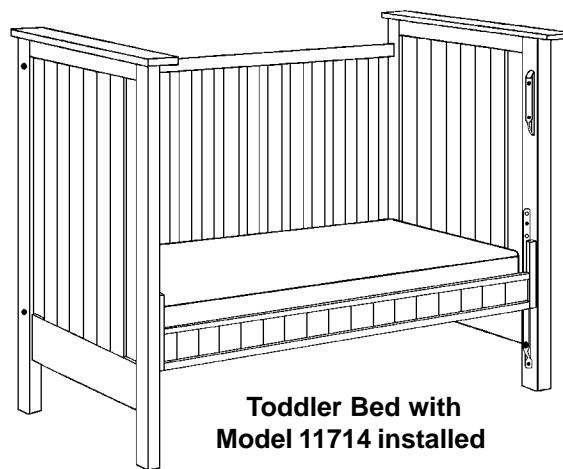

**MAINTENANCE OF YOUR CHILD CRAFT CRIB/TODDLER BED:** Upon completion of assembly be sure all screws, bolts and fastening devices have been tightened securely. A frequent check should be made of all screws, bolts and fastening devices and tightened if needed. Before each usage or assembly, inspect crib for damaged hardware, loose joints, missing parts or sharp edges. **DO NOT** use crib if parts are missing or broken. Contact Pottery Barn Kids or write to Child Craft Industries, Inc., P.O. Box 444, Salem, IN 47167 USA for a replacement part or instructional literature if needed. Include Model Identification Number with your request which you recorded on page 1 of these instructions. **DO NOT SUBSTITUTE PARTS. DO NOT MAKE ANY ALTERATIONS NOT DESCRIBED IN THESE ASSEMBLY DIRECTIONS.**

**CLEANING INSTRUCTIONS FOR YOUR CHILD CRAFT CRIB/TODDLER BED:** Mix together a mild solution of gentle dishwashing liquid and water, apply to surface using a soft clean cloth lightly dampened in the solution. Rinse with clear water again using a soft clean cloth, then dry all surfaces thoroughly with a soft dry cloth. **NO ABRASIVE CLEANERS, SCOURING PADS, STEEL WOOL, OR COARSE RAGS SHOULD BE USED TO CLEAN THIS FINE FURNITURE.**

**STORAGE AND USE OF YOUR CHILD CRAFT CRIB/TODDLER BED:** A printed plastic pouch is attached to the crib spring for the permanent storage of the assembly directions. After completing the assembly process you are advised to read and be aware of all **WARNINGS, CAUTIONS, CLEANING, STORAGE, USE AND MAINTENANCE** notices contained in this set of directions and printed on the plastic pouch located on the underneath side of the crib spring. You will then place the complete set of assembly directions into the plastic pouch for future referral. We caution you not to place excess hardware in the plastic pouch as it could present danger to a child if retrieved. When storing crib use **CAUTION** as extreme temperature or humidity changes could be harmful. Use **CAUTION** when a vaporizer is in use, always aim vapor stream away from crib as well as away from any wood furniture item.

## **⚠ WARNING**

Φ FAILURE TO FOLLOW THESE WARNINGS AND ASSEMBLY INSTRUCTIONS COULD RESULT IN SERIOUS INJURY OR DEATH.

Φ READ ALL INSTRUCTIONS BEFORE ASSEMBLING CRIB. KEEP INSTRUCTIONS FOR FUTURE USE. A PLASTIC POUCH IS ATTACHED TO CRIB FOR PERMANENT STORAGE OF THE INSTRUCTIONAL LITERATURE.

Φ BEFORE EACH USAGE OR ASSEMBLY, INSPECT CRIB FOR DAMAGED HARDWARE, LOOSE JOINTS, MISSING PARTS OR SHARP EDGES. DO NOT USE CRIB IF ANY PARTS ARE MISSING OR BROKEN. ASK YOUR POTTERY BARN KIDS DEALER OR WRITE TO Child Craft Industries, Inc., P.O. Box 444, Salem, IN 47167 USA FOR REPLACEMENT PARTS AND INSTRUCTIONAL LITERATURE IF NEEDED. INCLUDE MODEL IDENTIFICATION NUMBERS WITH YOUR REQUEST WHICH YOU RECORDED ON PAGE ONE. DO NOT SUBSTITUTE PARTS.

Φ AFTER RAISING SIDE, MAKE SURE LATCHES ARE SECURE.

Φ WHEN CHILD IS ABLE TO CLIMB OUT OR REACHES THE HEIGHT OF 35 INCHES (90 CENTIMETERS) THE CRIB SHALL NO LONGER BE USED.

Φ DO NOT PLACE CRIB NEAR WINDOW WHERE CORDS FROM BLINDS OR DRAPES MAY STRANGLE A CHILD.

Φ IF REFINISHING, USE A NON-TOXIC FINISH SPECIFIED FOR CHILDREN'S PRODUCTS.

Φ DO NOT LEAVE CHILD IN CRIB WITH SIDE LOWERED. BE SURE SIDE IS IN RAISED AND LOCKED POSITION WHENEVER CHILD IS IN CRIB.

Φ WHEN CHILD IS ABLE TO PULL TO STANDING POSITION, SET MATTRESS TO LOWEST POSITION AND REMOVE BUMPER PADS, LARGE TOYS AND OTHER OBJECTS THAT COULD SERVE AS STEPS FOR CLIMBING OUT.

Φ NEVER USE PLASTIC SHIPPING BAGS OR OTHER PLASTIC FILM AS MATTRESS COVERS BECAUSE THEY CAN CAUSE SUFFOCATION.

Φ DO NOT USE A WATER MATTRESS WITH THIS CRIB.

Φ REPLACE TEETHING RAIL(S) IF DAMAGED OR LOOSE. (IF EQUIPPED WITH TEETHING RAILS.)

Φ STRINGS CAN CAUSE STRANGULATION! DO NOT PLACE ITEMS WITH A STRING AROUND A CHILD'S NECK, SUCH AS HOOD STRINGS OR PACIFIER CORDS. DO NOT SUSPEND STRINGS OVER A CRIB OR ATTACH STRINGS TO TOYS.

Φ REMOVE ALL CRIB TOYS WHICH ARE STRUNG ACROSS CRIB AREA WHEN YOUR CHILD IS BEGINNING TO PUSH UP ON HANDS AND KNEES OR IS 5 MONTHS OF AGE, WHICHEVER OCCURS EARLIEST. THESE TOYS CAN CAUSE STRANGULATION.

Φ WHEN DISASSEMBLING THIS CRIB, DO NOT REMOVE ANY ITEM ATTACHED WITH WOOD SCREWS.

Φ ALWAYS ENSURE A SAFE ENVIRONMENT FOR THE CHILD BY CHECKING REGULARLY, BEFORE PLACING THE CHILD IN THE CRIB, THAT EVERY COMPONENT IS PROPERLY AND SECURELY IN PLACE.

## **CAUTION**

Φ ANY MATTRESS USED IN THIS CRIB MUST BE AT LEAST 27-1/4 INCHES (69 CENTIMETERS), BY 51-5/8 INCHES (131 CENTIMETERS), WITH A THICKNESS NOT EXCEEDING 6 INCHES (15 CENTIMETERS). THE DIMENSIONS OF THE MATTRESS SHALL BE TAKEN FROM SEAM TO SEAM OR EDGE TO EDGE WHERE APPROPRIATE.

Φ UPON COMPLETION OF ASSEMBLY BE SURE ALL SCREWS, BOLTS AND FASTENING DEVICES HAVE BEEN TIGHTENED SECURELY. A FREQUENT CHECK SHOULD BE MADE OF ALL SCREWS, BOLTS AND FASTENING DEVICES AND TIGHTEN IF NEEDED.

CCH02718:04/00JCHE.p65

MADE IN USA

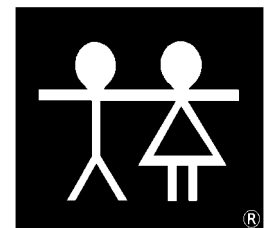

**CHILD CRAFT  
INDUSTRIES, INC.**  
P.O. BOX 444  
SALEM, IN 47167-0444 USA  
PH:812-883-3111  
FAX:812-883-1819  
<http://www.childcraftind.com>