



FOREVER
Eclectic

THIS IS THE ASSEMBLY
INSTRUCTIONS FOR CRIBS
SOLD IN THE
UNITED STATES

London Mini Folding Crib

Model Covered: F60001



Foundations Worldwide, Inc.
5216 Portside Dr.,
Medina, OH 44256 USA
PH: 1 330.722.5033
FAX: 1 330.722.5037
www.forever-eclectic.com



ASSEMBLY ASSISTANCE

Foundations strives for the highest quality in our products but occasionally a missing part or problem can occur during assembly. If any parts are missing or broken or you need assistance with assembly, DO NOT return the product to your dealer. Go to our website at www.foundations.com or call Foundations for assistance at 1-877-716-2757 (U.S. Only) or 1-330-722-5033 (Monday through Friday, 9:00 a.m. - 4:00 p.m. Eastern Time). Please have the model number and manufacture date available when you call or write us at: Foundations, 5216 Portside Dr. Medina OH 44256

PARTS LIST

Part Description	Part Number	Quantity
A. Allen Head Bolt 6mm x 55mm	11200984	8
B. Allen Head Bolt 6mm x 17mm	11201011	3
C. Allen Head Bolt 6mm x 10mm	11201012	4
D. Connector Nut	11201013	4
E. Connector Nut	11201014	2
F. Joint Connector Nut	11200970	8
G. 1.5 inch Caster	12100106	2
H. 1.5 inch Caster with Brake	12100107	2
I. Pivot Bracket	11200980	2
J. Allen Wrench	11200978	2
K. Back Assembly	22302881	1
L. Front Assembly	22302882	1
M. Short Foot Assembly	22302892	1
N. Short Head Assembly	22302898	1
P. Mattress Support	22302908	1
Q. Mattress	21100012	1

ASSEMBLY INSTRUCTIONS

- Adult assembly required.
- Read all instructions BEFORE assembly and USE of product.
- A number 2 size flat blade screwdriver is required.
- This crib meets the requirements of the Consumer Products Safety Commission standard for cribs and will provide many years of service provided you adhere to the following guidelines for assembly, maintenance and operation.

FOR CUSTOMER SERVICE CALL
1-877-716-2757
(outside of U.S. 330-722-5033). DO NOT CALL
RETAILER OR RESELLER FOR SERVICE
AS THEY ARE NOT AUTHORIZED TO
RESOLVE ANY SERVICE ISSUES.

**FOR WARRANTY AND FEDERAL SAFETY STANDARD
COMPLIANCE CERTIFICATES, PLEASE VISIT OUR
WEBSITE AT**
www.forever-eclectic.com

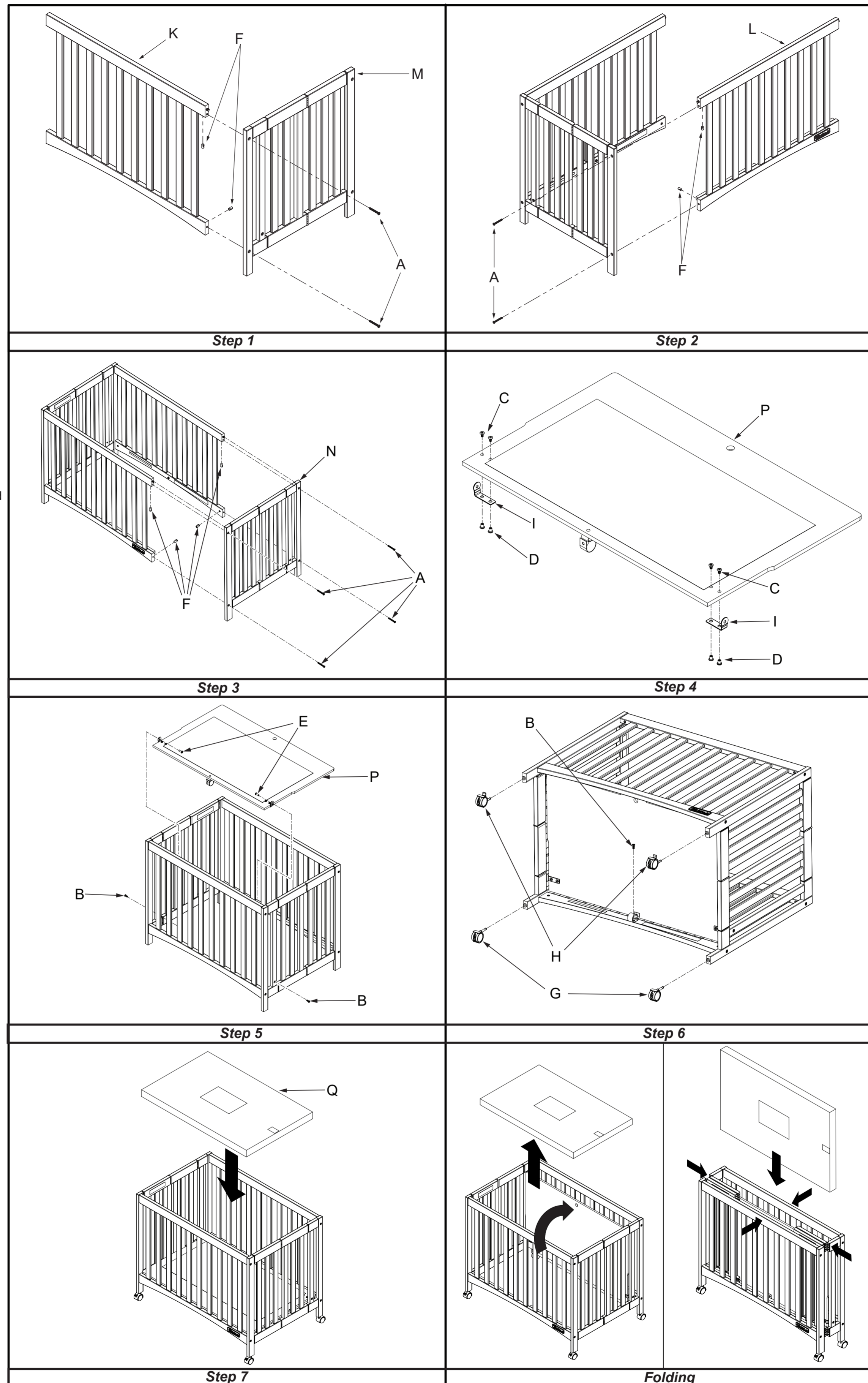
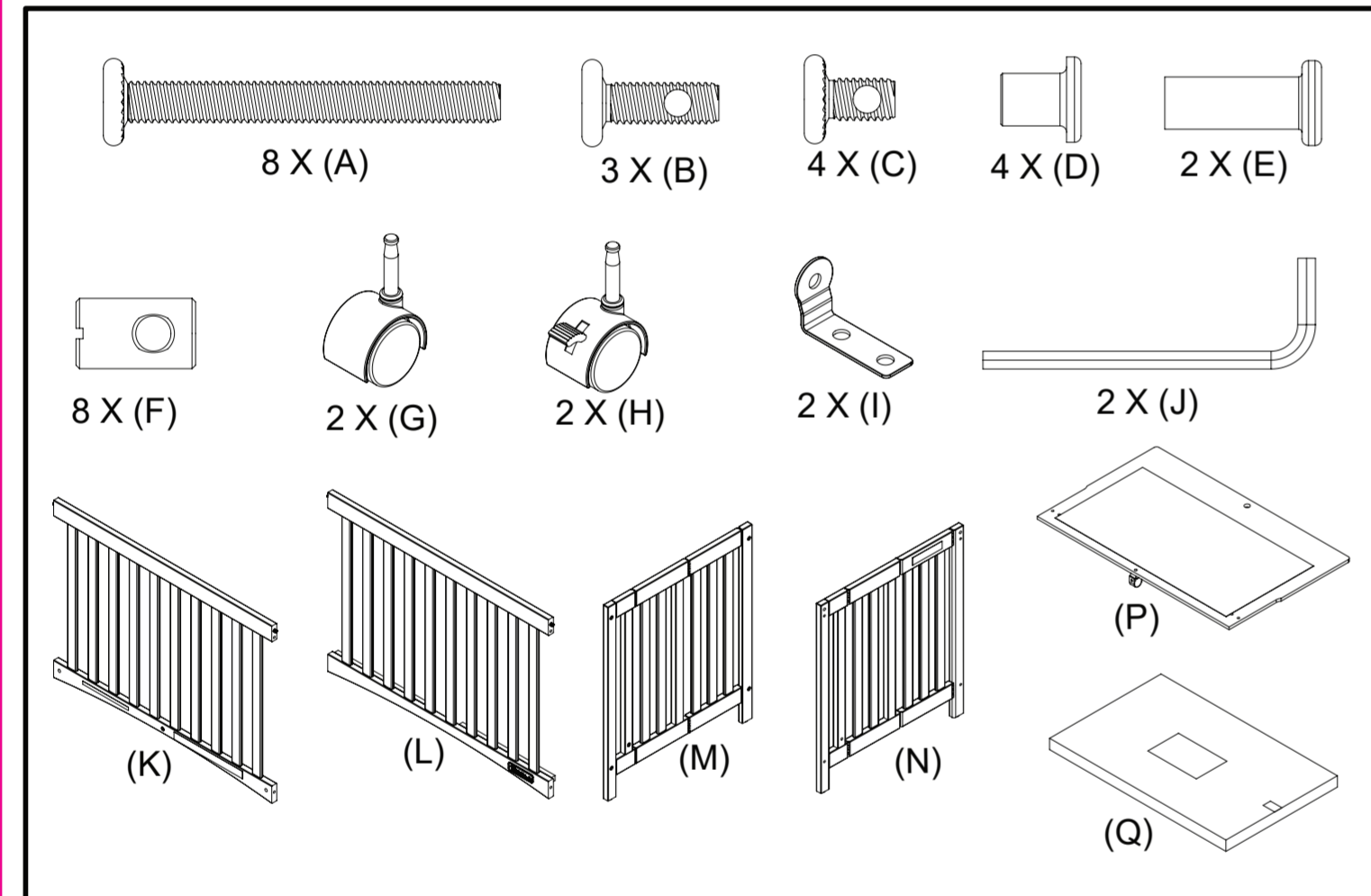

WARNING
Failure to follow these warnings and the instructions could result in serious injury or death!

- The crib, including side rails must be fully erected prior to use.
- Strings can cause strangulation! NEVER place items with a string around a child's neck such as hood strings or pacifier cords. NEVER suspend strings over crib or attach strings to toys.
- Discontinue use of the crib when child is able to climb out or reaches the height of 35 inches (890 mm).
- Child can become entrapped and die when improvised netting or covers are placed on top of product. NEVER add such items to confine child in product.
- When child is able to pull to standing position, remove bumper pads, large toys, and other objects that could serve as steps for climbing out.
- NEVER place crib near window where cords from blinds or drapes can strangle a child.
- Use ONLY the mattress provided by the manufacturer (which must be at least 37-3/4 inches (96 cm) long by 23-3/4 inches (60.4 cm) wide and not more than 3 inches (7.6 cm) thick.
- Always provide the supervision necessary for the continued safety of your child.
- When used for playing, NEVER leave child unattended.
- To reduce the risk of SIDS, pediatricians recommend healthy infants be placed on their back to sleep, unless otherwise advised by your physician.
- NEVER use this product if there are any loose or missing fasteners, loose joints, broken parts, or torn mesh/fabric. Check before assembly and periodically during use. Contact Foundations for replacement parts. Never substitute parts.
- NEVER use plastic shipping bags or other plastic film as mattress covers not sold and intended for that purpose. They can cause suffocation.
- NEVER use a water mattress with this crib.
- If refinishing, use a non-toxic finish specified for children's products.
- DO NOT use crib near objects that child could reach or pull into crib and cause injury such as lamps, heaters, fireplaces, or ironing boards.
- To avoid injuries, do not allow children to climb or play on or under the crib.

WARNING
Infants can suffocate

- In gaps between a mattress too small or too thick and sides of crib.
- On soft bedding.
- NEVER add a mattress, pillow, comforter or padding.

Maintenance Cleaning and Storage

MAINTENANCE:
Upon completion of the assembly, check to make sure all screws, bolts and connectors are tightened and secure. Periodically check crib for damaged hardware, loose joints, missing parts or sharp edges before and after assembly and frequently during use. DO NOT use crib if any parts are missing or broken. If any parts are missing, broken or you need assistance DO NOT return crib to your dealer. Call Foundations at 330.722.5033 and include model identification numbers. DO NOT substitute parts.

CLEANING:
Mix a mild solution of gentle dishwashing soap and water, apply to surface using a clean cloth lightly dampened in the solution. Rinse well with clear water using a soft clean cloth, then dry all surfaces with a soft dry cloth. DO NOT use abrasive cleaners or any cleaners with harsh chemicals that would contact a child's skin, scouring pads, steel wool or coarse rags. This crib should be treated the same as any fine furniture.

STORAGE:
When storing crib use Caution as extreme temperature or humidity changes could be harmful. Use caution when a vaporizer is in use. Always aim vapor stream away from crib as well as away from any furniture item. After completing the assembly the user is advised to read and be aware of ALL WARNINGS, CAUTIONS, CLEANING, STORAGE USE AND MAINTENANCE notices in these directions.

**THIS IS THE TOP SURFACE
OF THE MATTRESS SUPPORT**

WARNING

Infants can suffocate if improperly fitted mattresses or improperly fitted sheets are used. Use only Foundations® replacement mattresses and sheets.

To purchase properly fitting mattresses and sheets, call 330-722-5033 or online at www.foundations.com or contact your authorized Foundations® dealer.

Part No.: AD20022C Product: London folding crib. Part Name: Assembly floor label Original Issue Date: 9/4/2018 Revision Date: 04/14/2021 Revision Level: C B. Added top surface note C. New views for steps 1 and 2 for better orientation. RDA 04/14/2021 ACN163	Size: 488mm x 660mm Label Type: Adhesive back paper. Background Color: White Print Color(s): PMS Black Arial Regular
--	--